

BLPG

BPSG

ULSG

ULSG3/6

LSUW N1 Muting K

LSUW NSR3-1 K /

LSUW N1 K

LSUW N1 DUO K

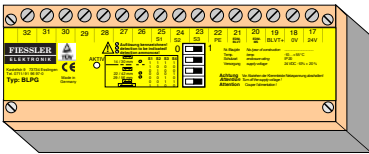

BLPG

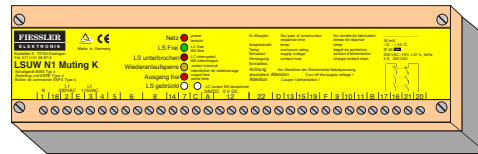

LSUW N1 Muting K

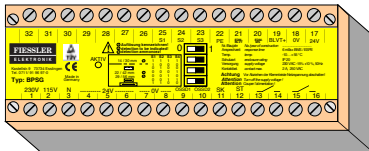

BPSG

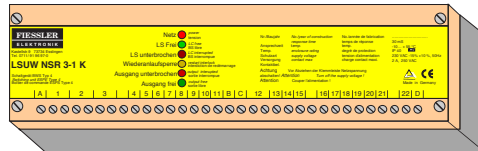

LSUW NSR 3-1 K

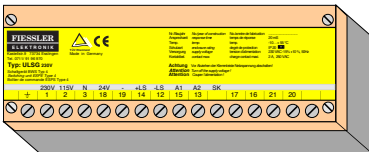

ULSG

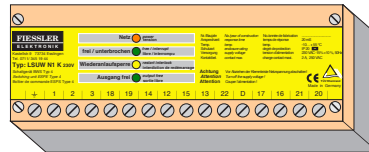

LSUW N1 K

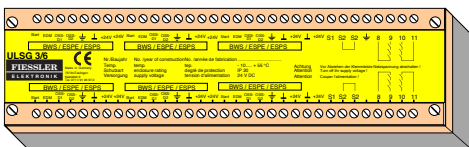

ULSG3/6

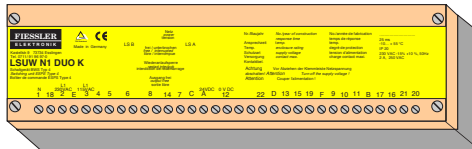

LSUW N1 DUO K

TABLE OF CONTENTS:

Safety instructions



Application notes

Installation

Electric connection

Commissioning

Technical specifications



BG
zugelassen



optional

For over 50 years,
we have specialized in the area of opto-electronics.
Our experience is your gain. Tell us your problems,
and we will be pleased to advise you.

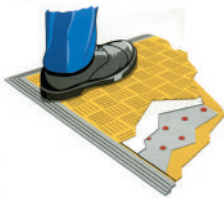

Footmats

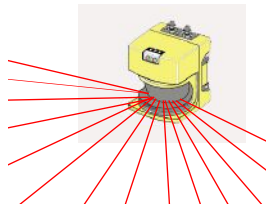

Laser scanners

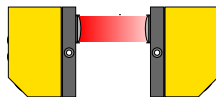

Single-beam safety light barriers with a long range (up to 150 m)



Press brake protection system AKAS®

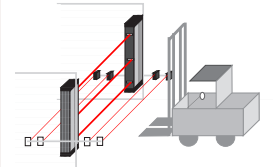

Differentiation between humans and machines by muting function

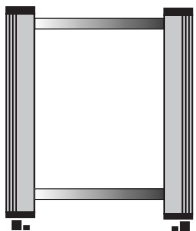

Two-beam light grids with a range of up to 60 m

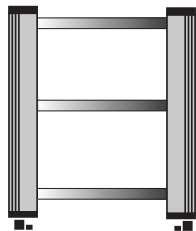

Three- or more beam light grids with a range of up to 60 m

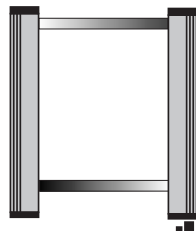

Two-beam light grids with transmitter / receiver units and a deflecting mirror with a range of up to 10 m

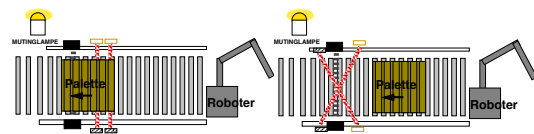

Output muting: Differentiation between humans and material

Cross-muting: Differentiation between humans and material / machines

Fiessler Elektronik GmbH & Co. KG
73773 Aichwald
Germany

Phone: +49(0)711-91 96 97-0
Fax: +49(0)711-91 96 97-50
Email: info@fiessler.de
Internet: www.fiessler.de

Represented in all major importing nations



Chapter	Contents	Page
1.	Safety instructions for all controllers 	4
1.1	Prerequisites for the use of safety light curtains / barriers	4
2.	Overview of safety controllers	52.1
	For safety light curtains ULVT / BLVT / TLVT / ILVT	52.2
	For safety light curtains and light barriers LSUW / EU2K / EU2K500/2	6
3.	BLPG and BPSG programming units and controllers	7
	BLPG: Programming unit for BLVT blanking functions; BPSG like BLPG, plus voltage supply and potential-free switching contacts	
4.	ULSG and ULSG 3/6 controllers	21
	ULSG: Contactor control, restart interlock, potential-free switching contacts	
	ULSG 3/6 like ULSG but with connections for up to 6 light curtains, only for 24 VDC	
5.	LSUW N1 Muting K controller	31
6.	LSUW NSR 3-1 K controller	41
	(5 operating modes)	
7.	LSUW N1 K controller	53
8.	LSUW N1 DUO K controller	59 (like
	the LSUW N1 K but with a connection for 2 light curtains)	
9.	Service	67



All safety instructions are marked with this symbol and must be observed in particular!



All instructions in this operating manual must be strictly observed. The manual provides the user with important information concerning proper use of the safety controllers.

Observe applicable standards and guidelines when using the safety controllers. Local authorities or trade associations will provide you with the relevant information. All other applicable regulations and standards issued by the employer's liability insurance associations must be observed too.

Qualified personnel Installation, commissioning and maintenance must only be carried out by qualified personnel.

Danger signs Before commissioning and operating a machine with a safety controller, ensure that nobody is located in the danger zone. A danger sign to this effect must be affixed to the machine.

Light barriers do not provide any protection against flying objects produced through operation of the machine.

During a use of safety light curtains with an external controller or other secondary control units, operative or organizational measures should ensure deactivation / testing at least once every 24 hours in order to detect and subsequently eliminate any faults on the controllers.

Ensure daily inspection (after 24 hours at the latest):

Using the test rod*, interrupt the light barrier on the transmitting side from the start to the end of the protective field so that the light field is only covered by this part. The green LED (or the yellow LED in the operating mode with restart interlock) must not light up from start to finish.

* The test rod's diameter must correspond to the detection capacity indicated on the receiver's type plate.

- The safety distance between the protective field and hazardous area must be large enough to ensure that, during entry into the protective field, the hazardous points cannot be reached before the hazardous movement is interrupted or ended.
- **Access to the hazardous area** must only be possible through the protective field (reaching under, over or around the field must not be possible).
- Passing through the light curtain must only be possible if the restart interlock is activated on interruption of the light curtain. A new command to activate the next hazardous machine movement must only be implemented via an enabling switch. This start button must not be operable from the hazardous area and must be located at a point from which the accessible area can be viewed without obstruction.
- It must be possible for the hazardous condition of a machine to be terminated by the sensor function.
- Unintentional repetition of a hazardous movement must be prevented by the appropriate safety facilities.
- The safety category (type 4) of the accident-prevention light curtain should be at least the same as the safety category of the machine control unit.
- Acceptance test:
The acceptance test for the installation should be carried out by competent personnel who are in possession of all information provided by the supplier of the machine and the BWS.
- Annual inspections:
The operator must ensure that a competent person is assigned the task of inspecting the light curtain and its machine interface on a yearly basis. This person may, for example, be employed by the light curtain's manufacturer or the operator.

On request by the customer, Finessler Elektronik carries out the acceptance test and annual inspections. In addition, seminars providing customers with training in annual inspections are held at regular intervals.

2. Overview of safety controllers

2.1 For safety controllers ULVT / BLVT / TLVT / ILVT

For functions such as muting, cyclical mode, potential-free output contacts etc., safety controllers are available for light curtains of series ULVT / BLVT / TLVT / ILVT.

The PLSG series can only be operated with ULVT and BLVT light curtains.



ULVT
or
BLVT

PLSG...

(separate
operating
manual)

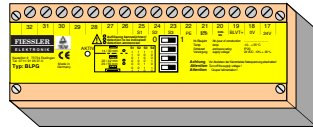

BLPG

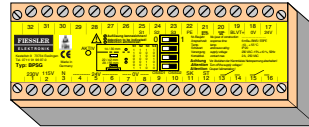

BPSG

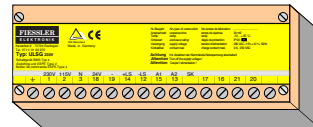

ULSG

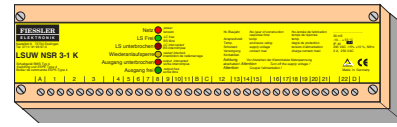

LSUW NSR 3-1 K

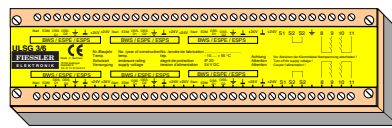

ULSG3/6

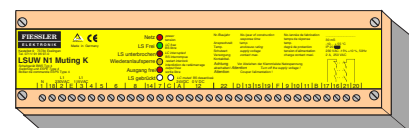

LSUW N1 Muting K

Safety controller	PLSG1 Muting safety controller	PLSG2 Muting safety controller	PLSG3 ^{Uni} versal controller	BLPG BLVT-pro- gram- ming unit	BPSG BLVT-pro- gram- ming unit	ULSG Controller	ULSG3/6 Controller	LSUWNSR 3-1K	LSUW N1 MutingK
Auxiliary functions									
Muting(brief bypass of the light curtain)	●	●	●						● Not for ULVT 500/2R
Cyclical operation Protective and control functions during cyclical entry into the protective field (for instance insertion ope- rations)			1-cycle,2- cycle, 3- cycle or 4- cycle					1-cycle or 2- cycle operation	
Potential-free switching contacts					●	●	●	●	●
Selector switch operation Changeover between operating mode and/or blanking modes			In conjunction with BLPG or BPSG; (see right)	Up to 5 PLSG operating modes / BLVT	Up to 5 PLSG operating modes / BLVT			Changeover between NSR 3-1 K operating modes	
Connection for 2 to 6 light curtains							●		
Restart interlock only during working motion			●					●	
BLVT blanking functionsPro- gramming of 11 blanking mo- des			●	●	●				
Emergency-stop circuit - Connection and monitoring			●						
Two-hand start switch - Connection and monitoring			●						
Override after irregular stop	●	●	●						
Connection voltage	24 VDC	24 VDC	24 VDC	24 VDC	24 VDC, 115 VAC, 230 VAC	24 VDC, 115 VAC, 230 VAC	24 VDC, 115 VAC, 230 VAC	24 VDC, 115 VAC, 230 VAC	24 VDC, 115 VAC, 230 VAC
Profile housing mountable on a light grid (only for ULVT and BLVT)	●	●	●						
Display 2 x 8 LCD characters		●	●						

2. Overview of safety controllers

2.2 For safety light curtains / barriers of type LSUW / EU2K /



For functions such as muting, cyclical mode, potential-free output contacts etc., safety controllers are available for light curtains / barriers of type LSUW, EU2K and EU2K500/2.

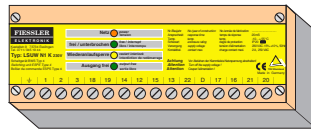

LSUW N1 K

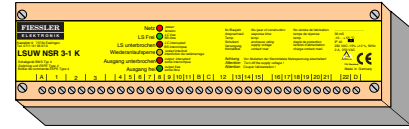

LSUW NSR 3-1 K

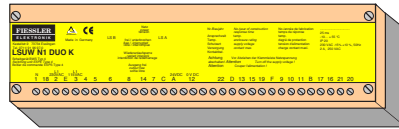

LSUW N1 DUO K

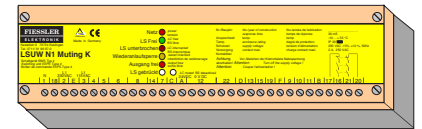

LSUW N1 Muting K

Safety controller	LSUW N1 K	LSUW N1 DUO K	LSUW N1 Muting K	LSUW NSR 3-1-K
Functions				
Muting(brief bypass of the light curtain)			●	
Cyclical operationProtective and control functions during cyclical entry into the protective field (for instance Insertion operations)				1-cycle or 2-cycle operation
Restart interlock	●	●	●	●
Restart interlock only during working motion				●
Contactur control	●	●	●	●
Potential-free switching contacts	●	●	●	●
Selector switch operation				
Changeover between 3 operating modes				●
Connection for 2 light curtains		●		
Connection voltage	24 VDC-version: 24 VDC, 230 VAC-version: 230 VAC	24 VDC, 115 VAC, 230 VAC	24 VDC, 115 VAC, 230 VAC	24 VDC, 115 VAC, 230 VAC

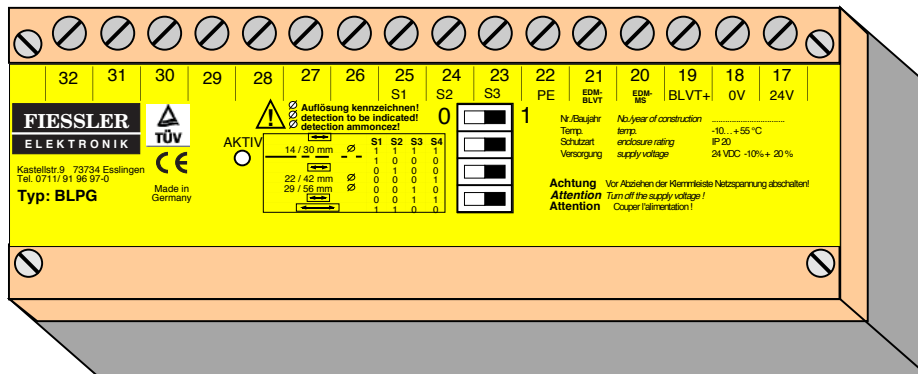

Programming unit BLPG

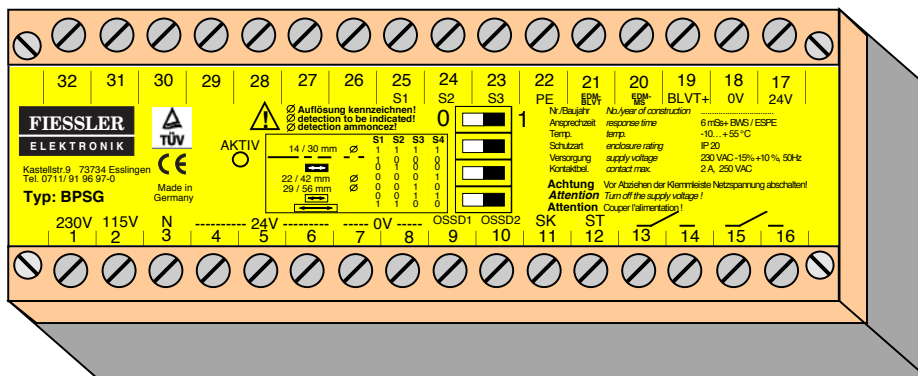

Programming and control unit BPSG

ChapterContentsPage

3. Blanking programming and control units BLPG / BPSG

3.1 Programming procedure	8
3.2 Connection of BLPG <u>with</u> restart interlock / <u>with</u> contactor control (EDM)	9
3.3 Connection of BLPG without restart interlock / <u>without</u> control of subsequent switching elements	9
3.4 Connection of BLPG <u>with</u> restart interlock / <u>without</u> control of subsequent switching element	10
3.5 Connection of BLPG <u>without</u> restart interlock / <u>with</u> contactor control (EDM)	10
3.6 Connection of BLPG in conjunction with a NSR 3-1 K controller.....	11
3.7 Connection of BPSG <u>with</u> restart interlock / <u>with</u> contactor control (EDM)	12
3.8 Connection of BPSG <u>with</u> restart interlock / <u>without</u> external contactors	13
3.9 Connection of BPSG <u>without</u> restart interlock / <u>without</u> control of subsequent switching elements	14
3.10 Connection of a selector switch to BLPG / BPSG	15
3.11 Storage and recall of up to 5 blanking modes in the BLVT light curtain	15
3.12 Connection of BLPG/BPSG to the PLSG universal controller and a selector switch.....	16
3.13 Storage and recall of up to 5 operating modes in the PLSG	17
3.14 Storage and recall of up to 5 operating modes in the PLSG; storage and recall of up to 5 blanking modes in the BLVT light curtain	17
3.15 Dimensional drawings	18
3.16 Technical specifications	19
3.17 Notes	20

3.1 Programming procedure (also refer to the BLVT operating manual)

BLPG: Blanking programming unit

A key switch is used to enable programming. The programming unit is not lutely necessary for operating the BLVT and can be removed again programming is complete..

BPSG: Blanking programming unit and controller

Like type BLPG, but also with a voltage supply and force-guided with potential-free outputs.

Instruction applies to **BPSG** and BLPG units (without a selector switch connection)

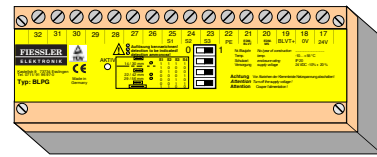

abso-
once

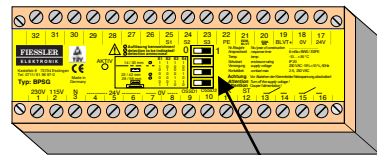

relay

Dip switch for setting the blanking mode

Programming must only be performed by authorized personnel. The key switch for enabling programming must be removed again immediately after programming is complete. The light curtain's current resolution must be clearly indicated on the accompanying sign.

1. Set the desired blanking mode using the DIP switches (refer to the BLVT operating manual).
2. Install barriers in the protective field. These are blanked after programming. The first beam (as seen from the plug) must not be dark, as it is needed to synchronize the transmitter and receiver. If beam 1 is covered during teach-in, the light curtain assumes the error state and the orange and yellow LEDs on the receiver start to flash rapidly (about 4 times per second).
3. Turn the key switch to the programming setting. Wait until the controller's green LED indicates readiness for programming (about 2 seconds).
4. Remove the key switch. Programming is complete once the green LED is deactivated.
5. Test the protective field with an appropriate rod. At any point in the field, this rod must deactivate the outputs. If the blanked areas do not cover the entire protective field, additional protective grids need to be installed.
6. Affix a sign indicating the current resolution.
7. The light curtain is now ready for operation. The dynamic blanking and reduced resolution operating modes are indicated by slow flashing (about once per second) of the adjustment aid and restart interlock LEDs on the receiver (with the protective field clear).

Blanking modes:	Dip switch			
	S1	S2	S3	S4
No blanking	1	1	1	1
Static blanking	1	0	0	0
Static blanking with 1-beam reduced resolution	1	0	0	1
Static blanking with 2-beam reduced resolution	1	0	1	0
Dynamic blanking (only 1 area possible)	0	1	0	0
Dynamic blanking with 1-beam reduced resolution	0	1	0	1
Dynamic blanking with 2-beam reduced resolution	0	1	1	0
1-beam reduced resolution	0	0	0	1
2-beam reduced resolution	0	0	1	0
Ignore 1 beam only once (full resolution for the remaining protective field)	0	0	1	1
Ignore 2 beams only once (full resolution for the remaining protective field)	1	1	0	0

 Important notes and constraints are provided in the BLVT operating manual.

3.2 Connection of BLPG with restart interlock / with contactor control (EDM)

Connection of BLVT light curtain:

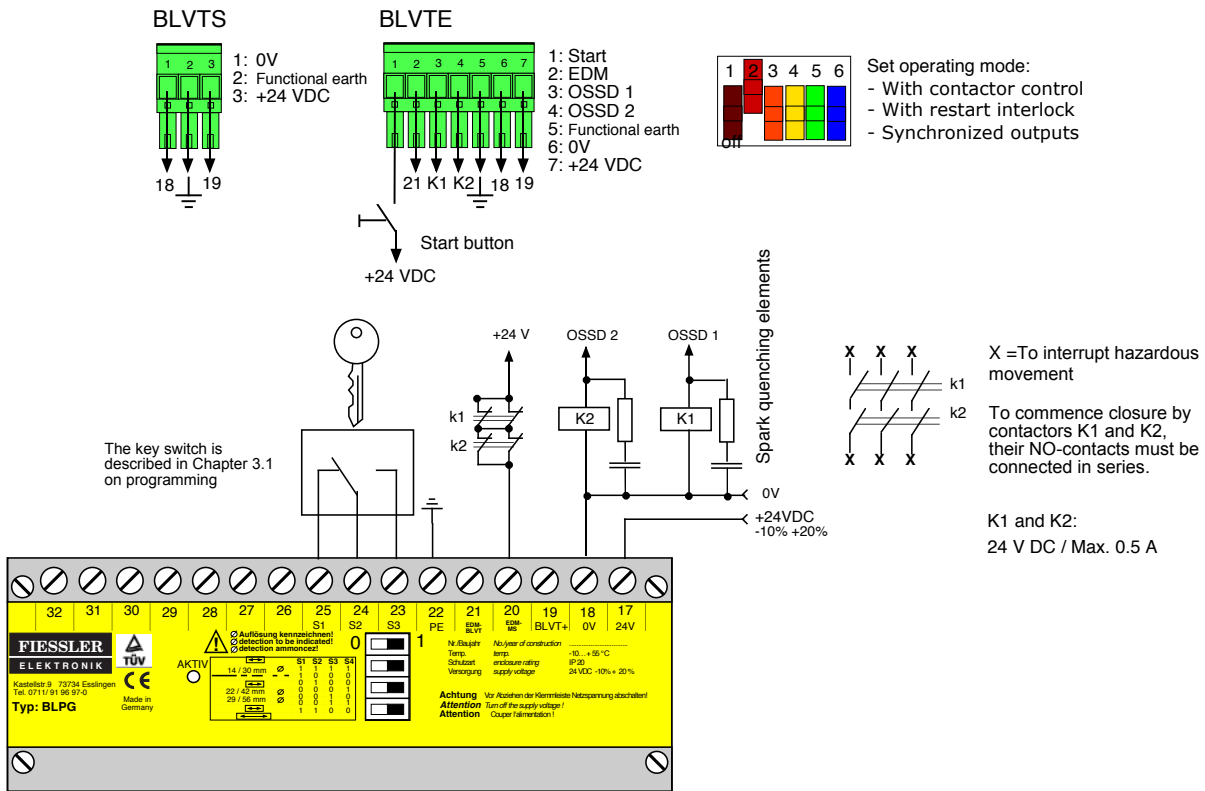

3.3 Connection of BLPG without restart interlock / without control of subsequent switching elements

Connection of curtain BLVT light curtain:

! A restart interlock must be provided for passable areas.

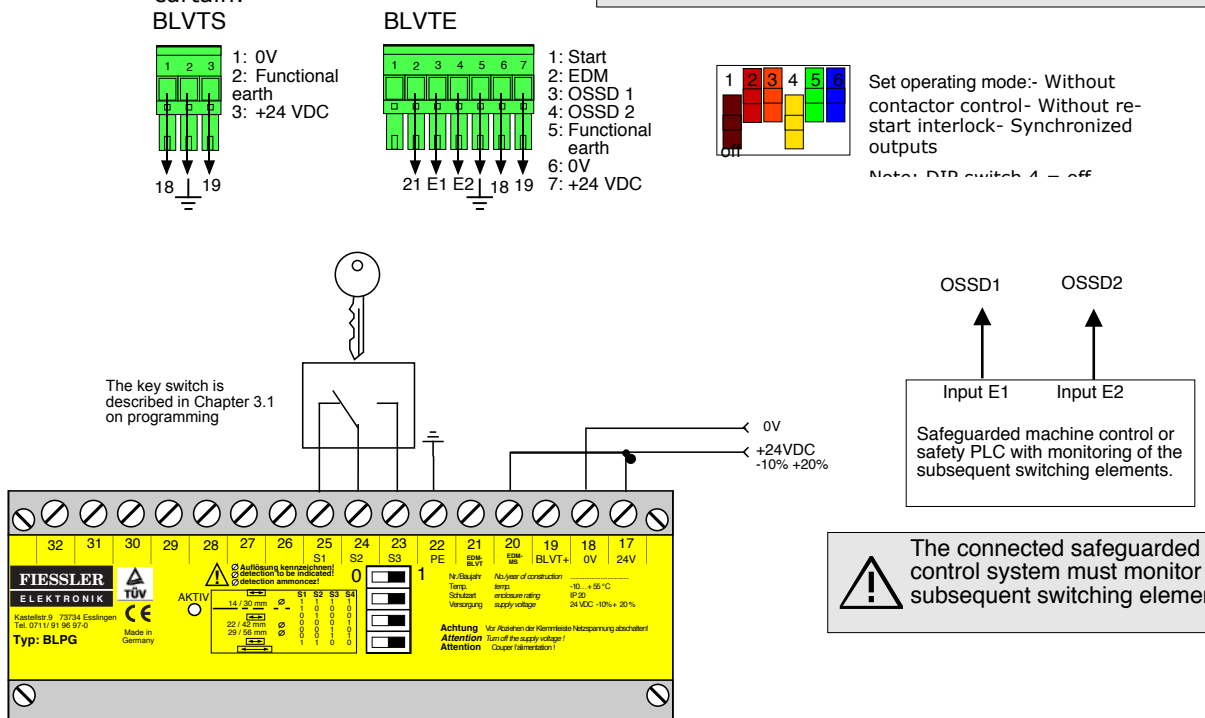

3.4 Connection of BLPG with restart interlock / without control of subsequent switching elements

Connection of BLVT light curtain:

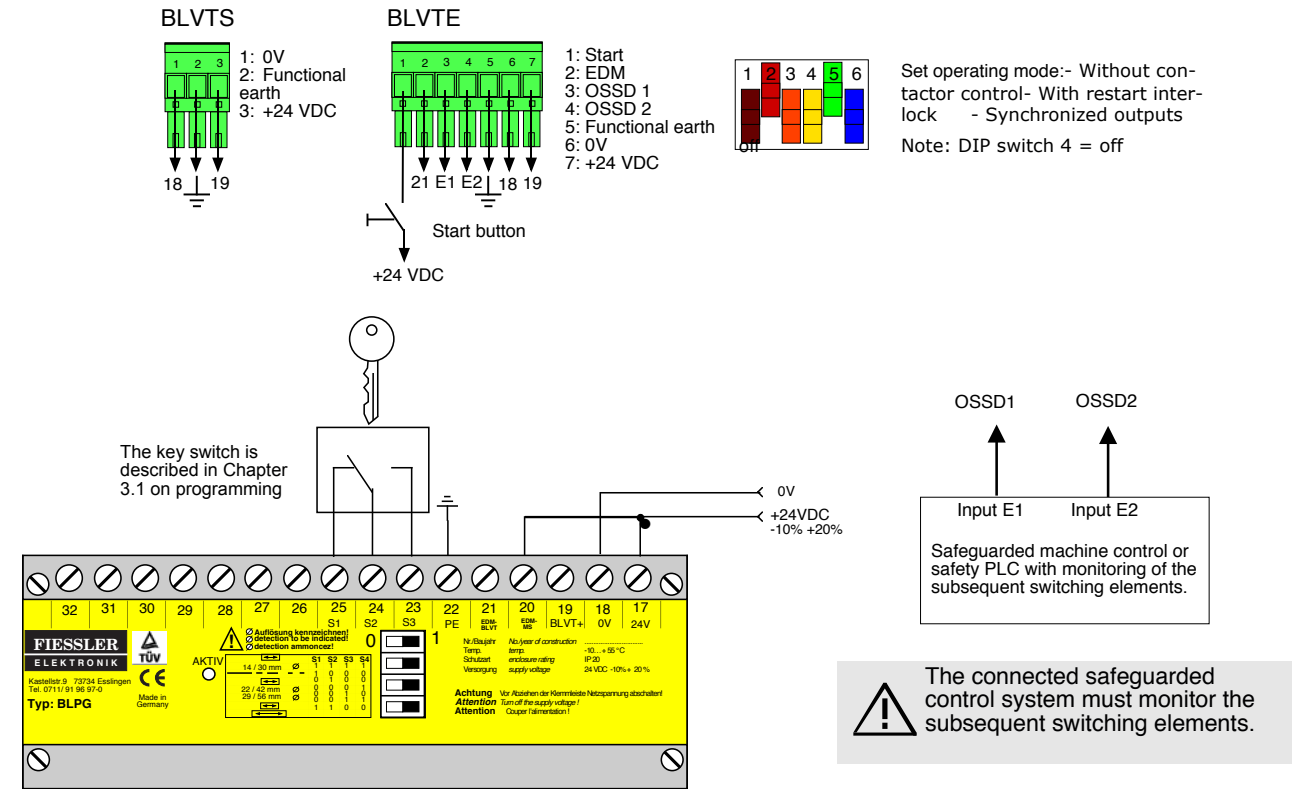

3.5 Connection of BLPG without restart interlock / with contactor control (FDM)

Connection of BLVT light curtain:

Warning: A restart interlock must be provided for passable areas.

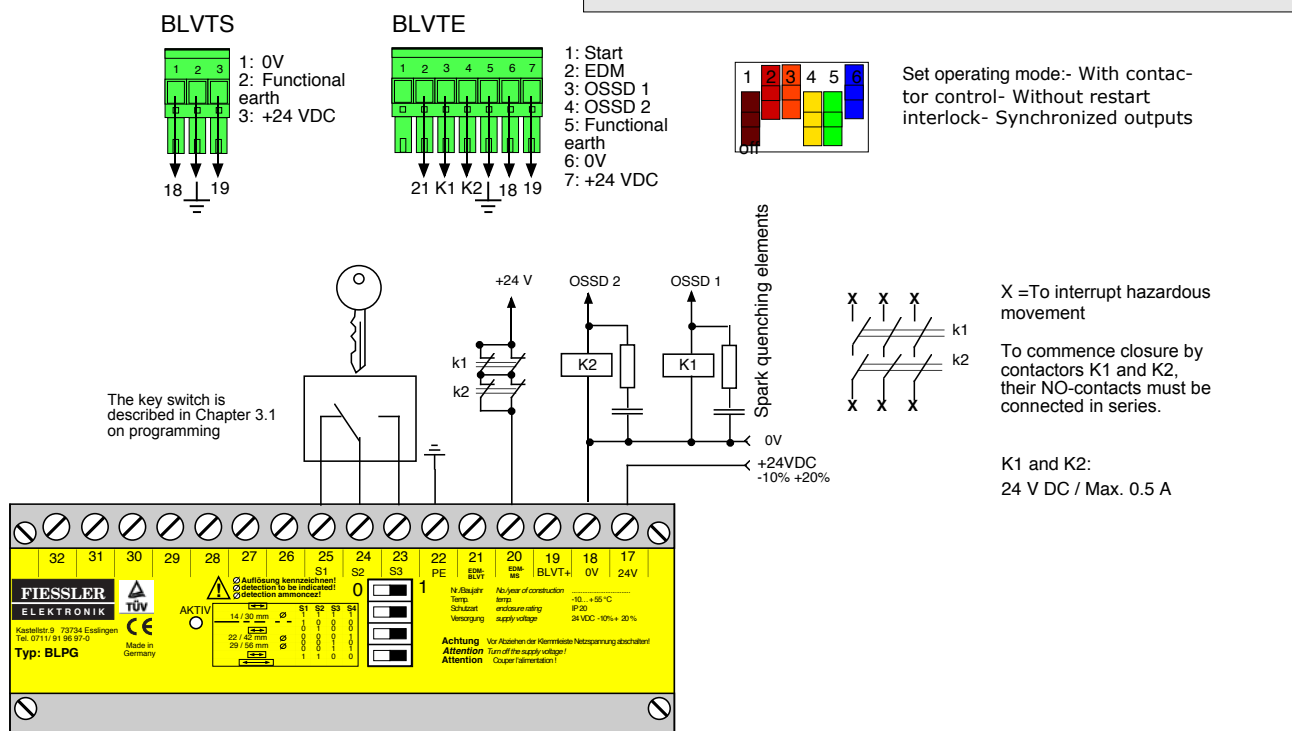

3.6 Connection of BLPG programming unit to NSR 3-1 K controller - Cyclic mode "A" (also refer to Chapter 5)

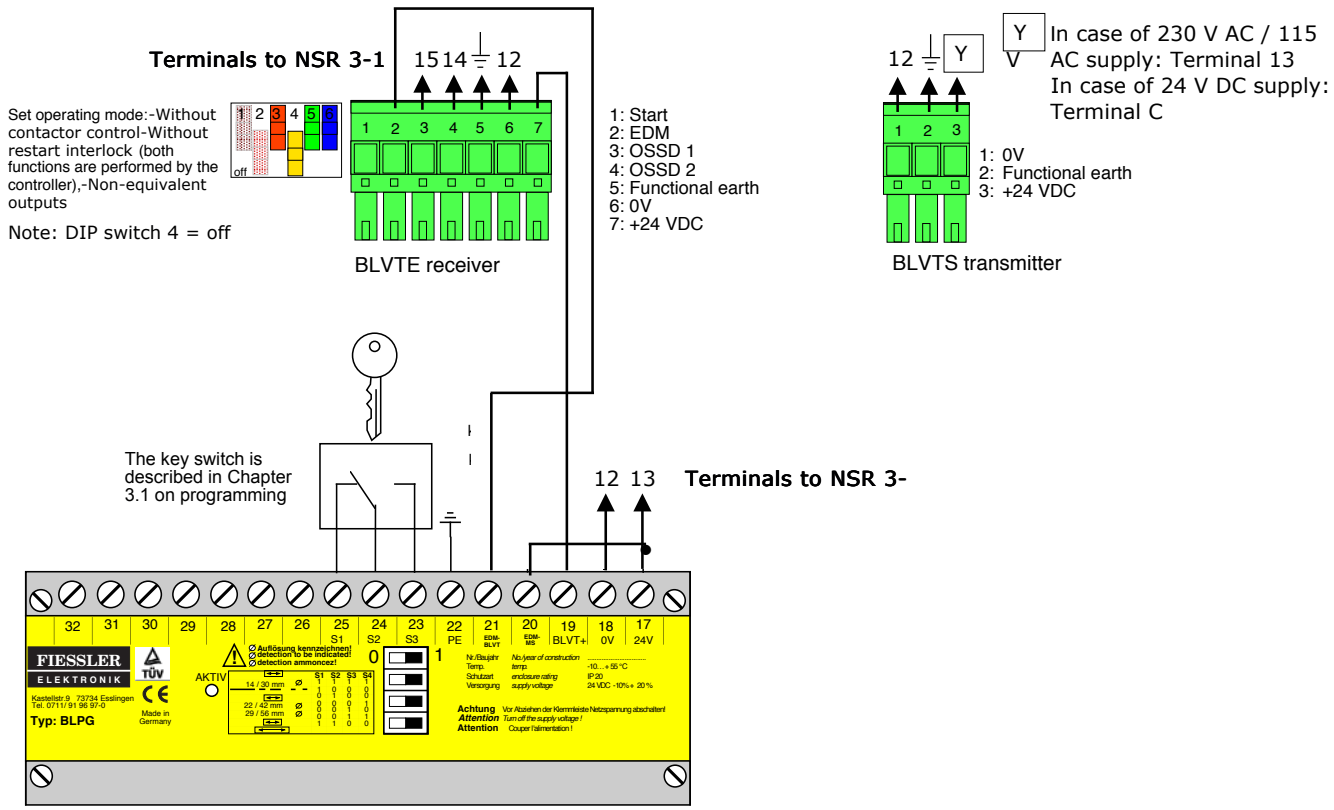
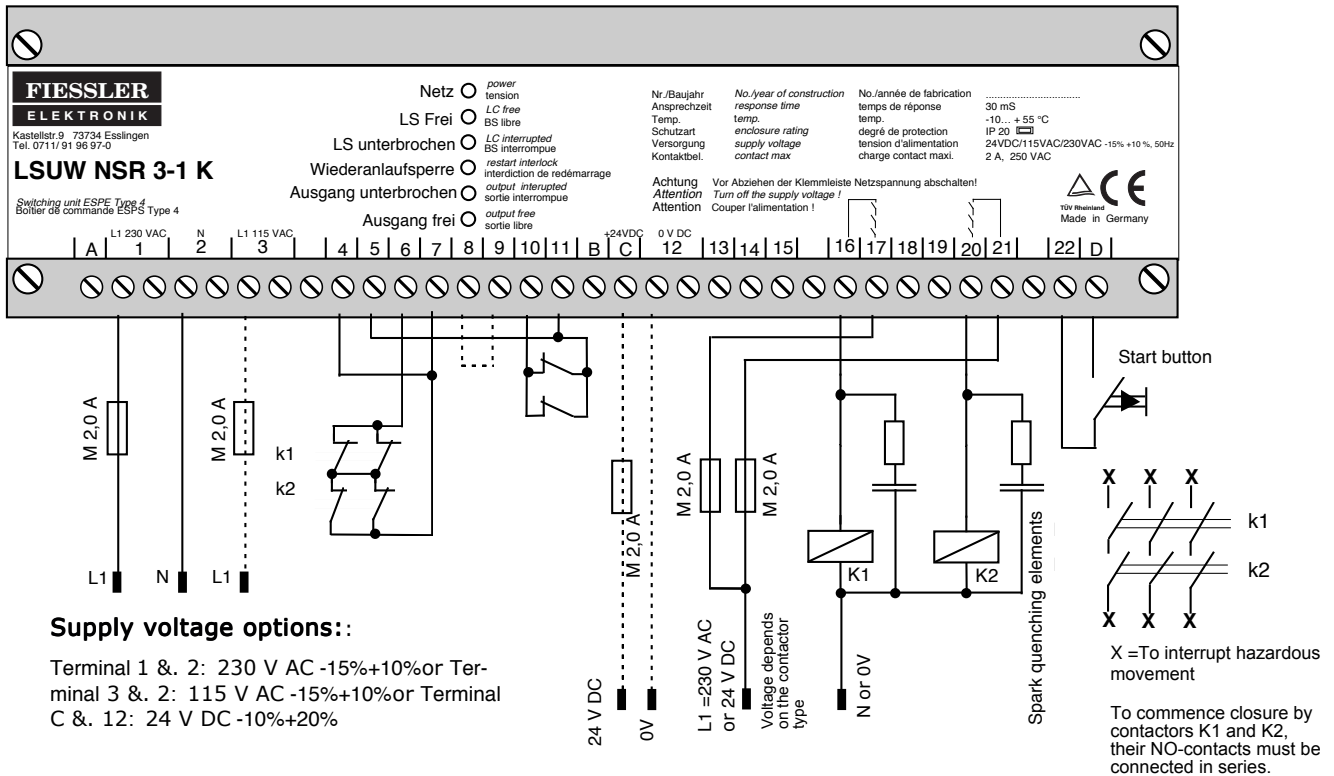

3.7 Connection of BPSG with restart interlock / with contactor control (EDM)(230 V AC, 115 V AC or 24 V DC)

The BPSG controller fulfils the power-failure bridging standard of 20 ms specified by EN 60204 and is therefore suitable for supplying the BLVT light curtain with voltage.

External contactors control hazardous movement

If the protective field is clear and the start button is operated, potential-free output contacts 13-14 and 15-16 close, and connected contactors K1 and K2 are engaged.

When controlling hazardous movements by means of contactors K1 and K2, connect their NO-contacts in series.

Connection pin 2 (EDM = contactor control) on the light curtain can be used to control the contactors or hydraulic valves K1 and K2 (control path: terminals 4 and 20 on the controller) which initiate the hazardous movement. If the protective field is infiltrated, the output contacts open and movement is interrupted. Operation can only be continued by actuating the start button. However, commencement of a new duty cycle or movement is only possible once both contactors / valves K1 and K2 have been released and the protective field is clear again.

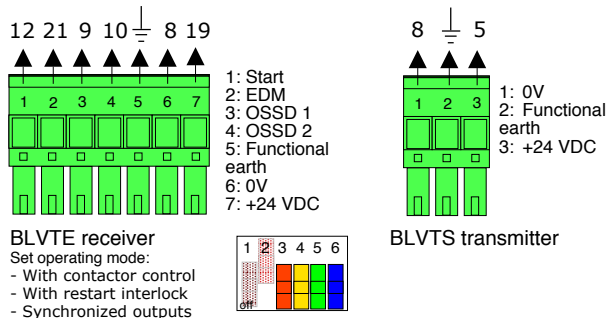
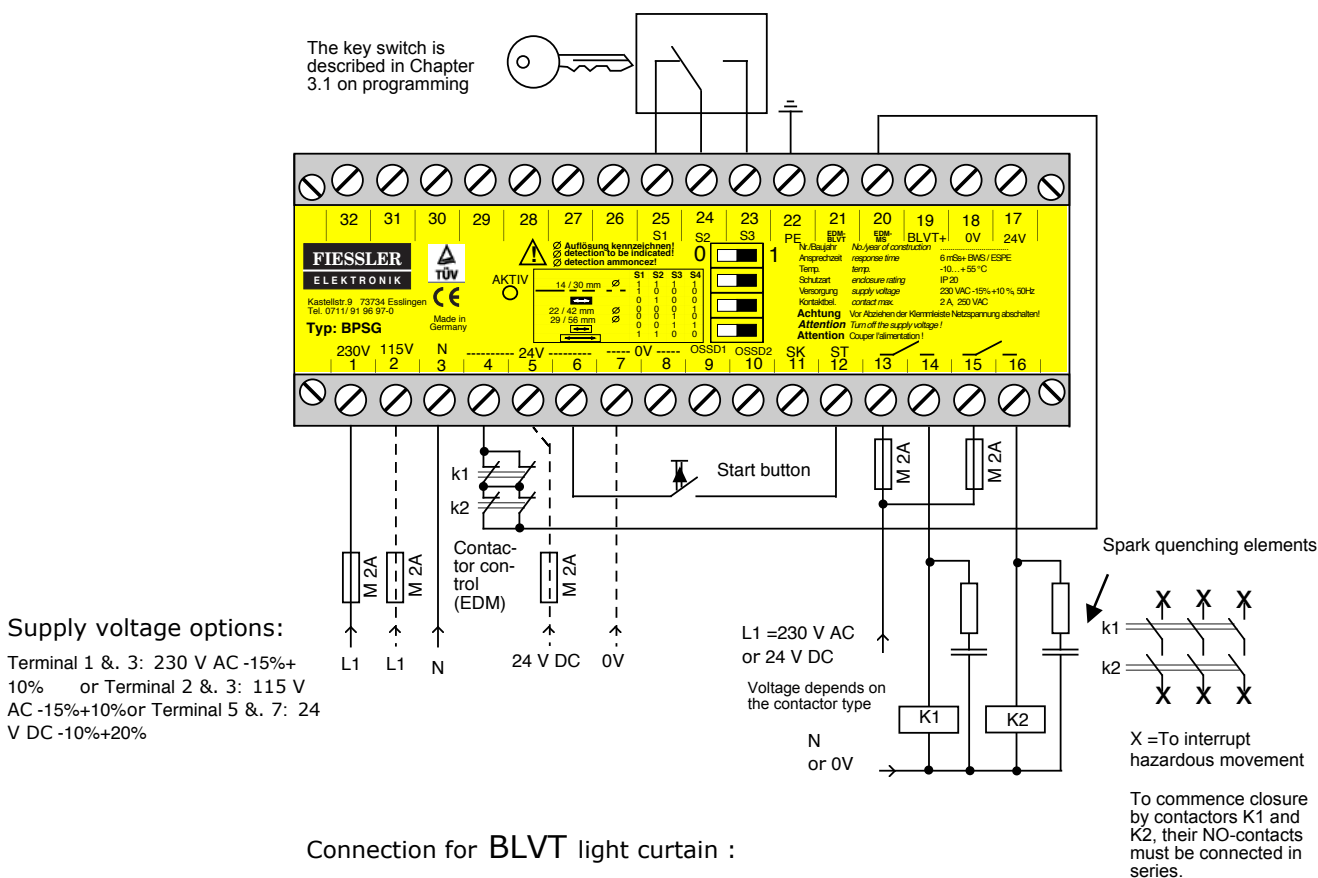

Cable installation: Separate from high-voltage lines.

Hazardous movements must only be performed via output contacts 13-14 and 15-16. These contacts are potential-free, force-guided and normally open with a maximum loading capacity of 2 A/250 V AC or 60 V DC, 30 W. If an inductive load is employed, it (not the contacts) must be connected in parallel with spark quenching elements (for

example, 0.22 μF, 220 Ω). No extraneous potential must be connected to terminal 9, 10, 11 or 12.

If electric welding needs to be performed on the machine, pull out the controller's terminal strip to prevent stray welding currents from damaging the integrated electronics.

3.8 Connection of BPSG with restart interlock / without external contactors (230 V AC, 115 V AC or 24 V DC connection)

The BPSG controller fulfils the power-failure bridging standard of 20 ms specified by EN 60204 and is therefore suitable for supplying the BLVT light curtain with voltage.

Output contacts 13-14 and 15-16 directly control hazardous movement.

If the protective field is clear and the start button is operated, potential-free output contacts 13-14 and 15-16 close, and movement is commenced. If the protective field is infiltrated, the output contacts open and movement is interrupted. Operation can only be continued by actuating the start button. However, commencement of a new duty cycle or movement is only possible once the protective field is clear again. Connection pin 2 (EDM = contactor control) on the light curtain can be used to additionally control the internal switching elements (13 - 14 and 15 - 16) which initiate hazardous movement.

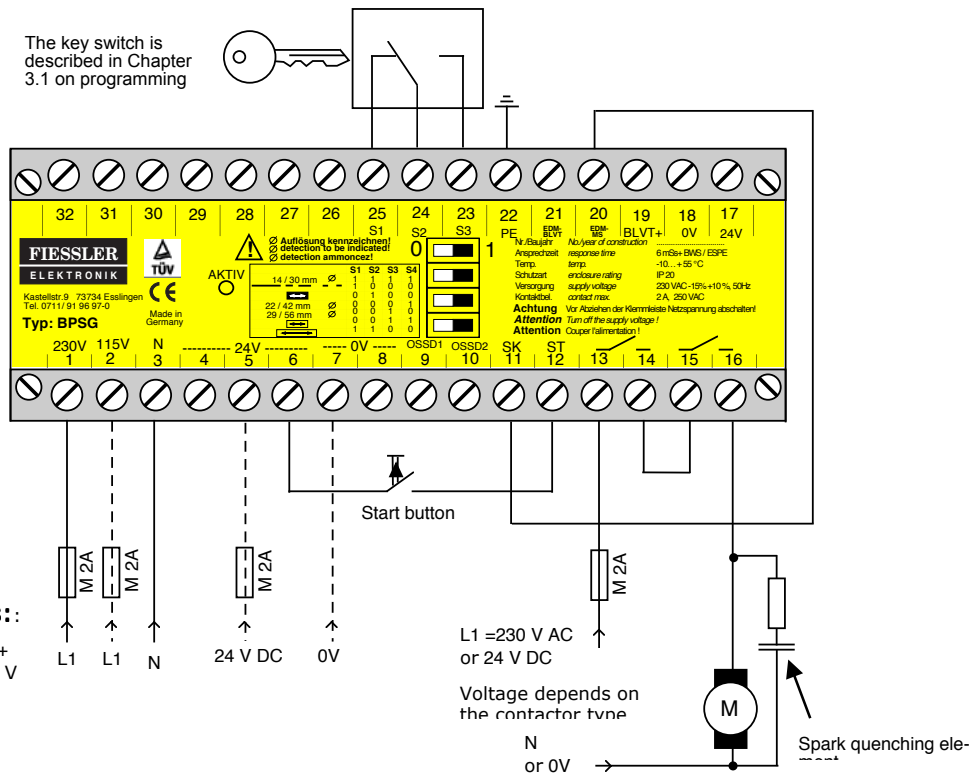

Connection for BLVTlight curtain :

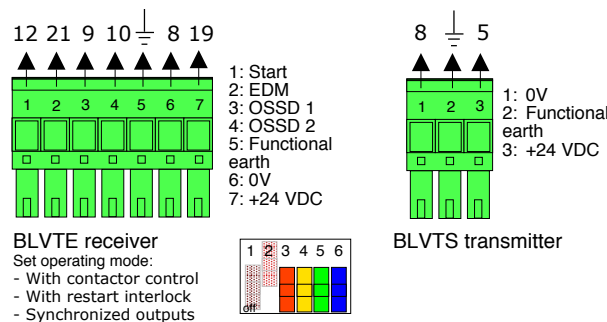

Cable installation: Separate from high-voltage lines.

Hazardous movements must only be performed via output contacts 13-14 and 15-16. These contacts are potential-free, force-guided and normally open with a maximum loading capacity of 2 A/250 V AC or 60 V DC, 30 W. If an inductive load is employed, it (not the contacts) must be connected in parallel with spark quenching elements (for

example, 0.22 μ F, 220 Ω). No extraneous potential must be connected to terminal 9, 10, 11 or 12.

If electric welding needs to be performed on the machine, pull out the controller's terminal strip to prevent stray welding currents from damaging the integrated electronics.

3.9 Connection of BPSG without restart interlock / without control of subsequent switching elements (230 V AC, 115 V AC or 24 V DC)

The BPSG controller fulfils the power-failure bridging standard of 20 ms specified by EN 60204 and is therefore suitable for supplying the BLVT light curtain with voltage.

If the protective field is infiltrated, output contacts 13 - 14 and 15 - 16 open. If the protective field is cleared, the output contacts close.

Connection pin 2 (EDM = contactor control) on the light curtain can be used to additionally control the internal switching elements (13 - 14 and 15 - 16) which initiate hazardous movement.



The connected, safeguarded control system must monitor the subsequent switching elements and possess a restart interlock depending on the application involved.

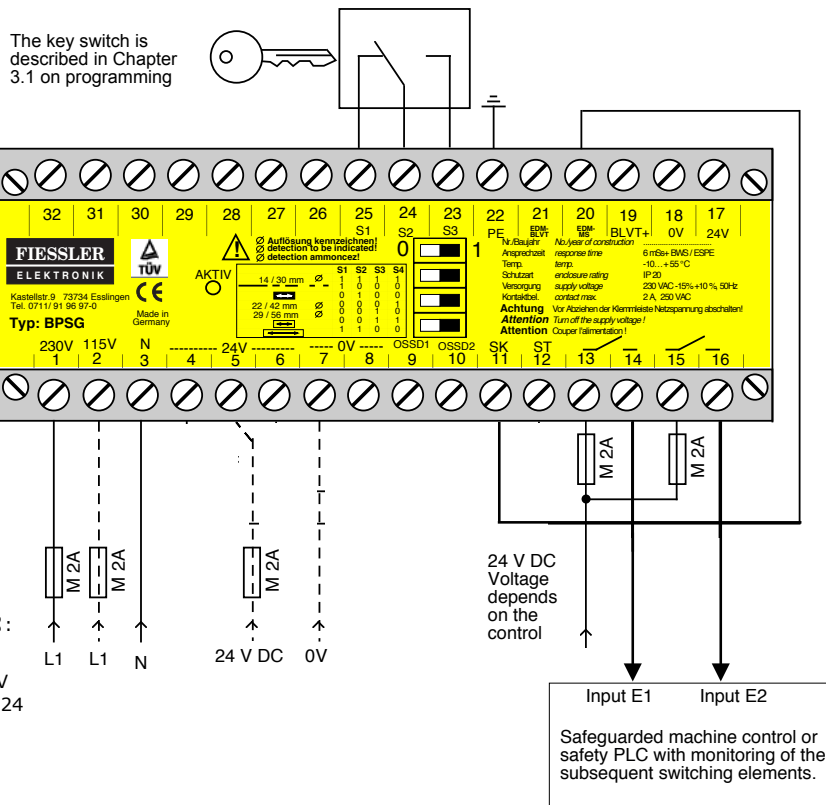

Connection for BLVT light curtain:

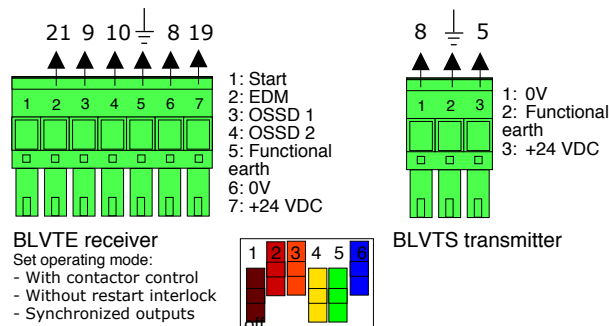

Cable installation: Separate from high-voltage lines.

Hazardous movements must only be performed via output contacts 13-14 and 15-16. These contacts are potential-free, force-guided and normally open with a maximum loading capacity of 2 A/250 V AC or 60 V DC, 30 W. If an inductive load is employed, it (not the contacts) must be connected in parallel with spark quenching elements (for

example, 0.22 μ F, 220 Ω). No extraneous potential must be connected to terminal 9, 10, 11 or 12.

If electric welding needs to be performed on the machine, pull out the controller's terminal strip to prevent stray welding currents from damaging the integrated electronics.

Also refer to the BLVT operating

3.10 Connection of a selector switch to the BLPG / BPSG programming unit

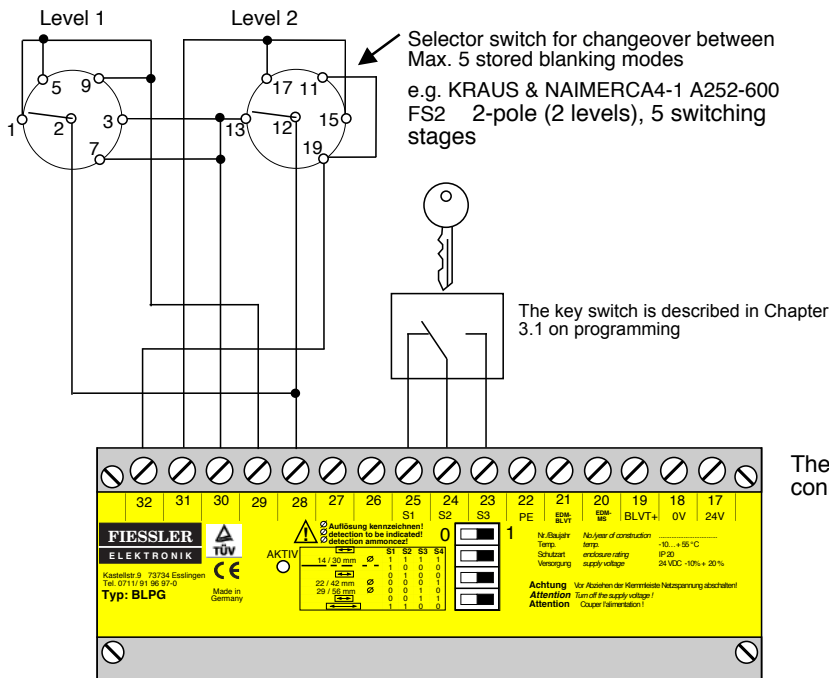

3.11 Storage of up to 5 blanking modes in BLVT and recall via a selector switch

Using an external selector switch in conjunction with the BLPG or BPSG programming unit, up to 5 different blanking functions can be stored in, and recalled from, the BLVT light curtain.

On switchover or an interruption in the voltage supply, the current blanking mode is retained in the light curtain until the selector switch is moved to a different setting and the key switch is operated again.

Programming procedure (applicable to BPSG and **BLPG** controllers):

Programming must only be performed by authorized personnel. The key switch for enabling programming must be removed again immediately after programming is complete. The light curtain's current resolution must be clearly indicated on the accompanying sign.

Refer to the BLVT operating manual for important notes and

0. Move the selector switch to the setting to be assigned to the BLVT blanking mode requiring teach-in.
1. Set the desired blanking mode using the DIP switches.
2. Install barriers in the protective field. These are blanked after programming. The first beam (as seen from the plug) must not be dark, as it is needed to synchronize the transmitter and receiver. If beam 1 is covered during teach-in, the light curtain assumes the error state and the orange and yellow LEDs on the receiver start to flash rapidly (about 4 times per second).
3. Turn the key switch to the programming setting. Wait until the controller's green LED indicates readiness for programming (about 2 seconds).
4. Remove the key switch. Programming is complete once the green LED is deactivated.
5. Test the protective field with an appropriate rod. At any point in the field, this rod must deactivate the outputs. If the blanked areas do not cover the entire protective field, additional protective grids need to be installed.
6. The light curtain is now ready for operation. The dynamic blanking and reduced resolution operating modes are indicated by slow flashing (about once per second) of the adjustment aid and restart interlock LEDs on the receiver (with the protective field clear).

The remaining selector switch assignments can be successively programmed in a similar manner.

Using the selector switch to change between various blanking modes:

1. Deactivate (= 0) all DIP switches.
2. Move the selector switch to the required position.
3. Perform steps 3, 4 and 5 (programming) as described above.

On switchover or an interruption in the voltage supply, the current blanking mode is retained in the light curtain until the selector switch is moved to a different setting and the key switch is operated again.

3.12 Connection of BLPG / BPSG to the PLSG 3 universal controller and a selector

switch Using an external selector switch in conjunction with the BLPG or BPSG programming unit, up to 5 different blanking functions can be stored in, and recalled from, the PLSG controller.

On switchover or an interruption in the voltage supply, the current operating mode is retained in the PLSG controller until the selector switch is moved to a different setting and the key switch is operated again.

The selector switch is connected as described in Chapter 3.10.

The PLSG 3 is connected like the BLVT receiver as depicted in the connection diagrams in the last chapter.

The pin assignment and connector design of the PLSG 3 are identical to those of the BLVT receiver.

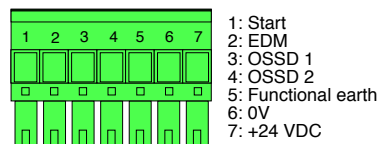

Connection of PLSG 3 corresponds to BLVTE

PLSG – refer to the operating manual

3.13 Storage and recall of up to 5 operating modes in the PLSG

Programming procedure:

Programming must only be performed by authorized personnel. The key switch for enabling programming must be removed again immediately after programming is complete.

1. Move the selector switch to the setting to be assigned to the PLSG operating mode.
2. Set the desired operating mode using the HEX switches on the PLSG.
3. Deactivate (= 0) all DIP switches on the BLPG / BPSG.
4. Move the key switch to the programming setting. Wait until the controller's green LED indicates readiness for programming (about 2 seconds).
5. Remove the key switch. Deactivation of the green LED indicates that programming is complete.
6. PLSG displays: "Mode // assigned" alternately with the chosen setting for the selector switch, for example, "Switch / mode 1".

The remaining selector switch assignments can be successively programmed in a similar manner..

Important: Before the PLSG is put into operation and switchover between the assigned operating modes is performed, the operating mode "Selector switch without BLVT assignment" (FF DD) must be set using the HEX switches on the PLSG. Furthermore, after one or more selector switch assignments have been programmed, a one-time request for the currently used selector switch setting must be issued. This is done similarly to the switchover procedure (refer to the next section).

Switchover between various operating modes in the PLSG:

1. Move the selector switch to the desired position.
2. Set "Selector switch without BLVT assignment" using the HEX switches of the PLSG (FF DD).
3. Deactivate (= 0) all DIP switches on the BLPG / BPSG.
4. Move the key switch to the programming setting. Wait until the controller's green LED indicates readiness for programming (about 2 seconds).
5. Remove the key switch. Deactivation of the green LED indicates that programming is complete.
6. The PLSG displays the selector switch setting for about 5 seconds, for example: "Switch // mode 1" and assumes the operating mode assigned to this setting.

On switchover or an interruption in the voltage supply, the current operating mode is retained in the light curtain until the selector switch is moved to a different setting and the key switch is operated again.

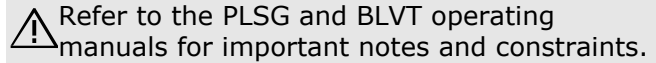

3. 13 Storage and recall of up to 5 operating modes in the PLSG; storage and recall of up to 5 blanking modes in the BLVT light curtain

Programming procedure

Programming must only be performed by authorized personnel. The key switch for enabling programming must be removed again immediately after programming is complete. The light curtain's current resolution must be clearly indicated on the accompanying sign.

1. Move the selector switch to the setting to be assigned to the PLSG operating mode and BLVT light curtain's blanking mode.
2. Set the desired operating mode using the HEX switches on the PLSG.
3. Set the DIP switches on the BLPG / BPSG to the desired BLVT blanking mode.
2. Install barriers in the protective field. These are blanked after programming.

The first beam (as seen from the plug) must not be dark, as it is needed to synchronize the transmitter and receiver. If beam 1 is covered during teach-in, the light curtain assumes the error state and the orange and yellow LEDs on the receiver start to flash rapidly (about 4 times per second).

4. Turn the key switch to the programming setting. Wait until the controller's green LED indicates readiness for programming (about 2 seconds).
 5. Remove the key switch. Programming is complete once the green LED is deactivated.
 6. The PLSG displays the selected blanking mode for several seconds, e.g. "variable // blanking". The red and orange LEDs on the BLVT come on.
 7. The PLSG displays: "Mode // assigned" alternately with the chosen selector switch setting, for example: "Switch // mode 1". The green LED on the BLVT comes on: depending on the blanking mode, the yellow and orange LEDs flash (variable blanking or reduced resolution).
 8. Test the protective field with an appropriate rod. At any point in the field, this rod must deactivate the outputs. If the blanked areas do not cover the entire protective field, additional protective grids need to be installed.
- The remaining selector switch assignments can be successively programmed in a similar manner.

Important: Before the PLSG is put into operation and switchover between the assigned operating modes is performed, the operating mode "Selector switch with BLVT assignment" (FF EE) must be set using the HEX switches on the PLSG and all DIP switches on the BLPG / BPSG must be set to 0. Furthermore, after one or more selector switch assignments have been programmed, a one-time request for the currently used selector switch setting must be issued. This is done similarly to the switchover procedure (refer to the next section).

Switchover between various operating modes in the PLSG: 1. Move the selector switch to the required setting.

2. Set "selector switch mode with BLVT assignment" using the HEX switches on the PLSG (FF EE). Deactivate (= 0) all DIP switches on the BLPG / BPSG.
3. Turn the key switch to the programming setting.
4. Wait until the controller's green LED indicates readiness for programming (about 2 seconds).
5. Remove the key switch. Programming is complete once the green LED is deactivated.
6. The PLSG displays the selector switch setting for about 5 seconds, for example: "Switch // mode 1" and assumes the operating mode assigned to this setting.
7. Test the protective field with an appropriate rod. At any point in the field, this rod must deactivate the outputs.
8. The light curtain is now ready for operation. The dynamic blanking and reduced resolution operating modes are indicated by slow flashing (about once per second) of the yellow / orange adjustment aid and restart interlock LEDs on the receiver (with the protective field clear).

On switchover or an interruption in the voltage supply, the operating mode and blanking mode are retained in the PLSG until the selector switch is moved to a different setting and the key switch is operated again.

If the connected BLVT should always have the same blanking mode, step 3 of the programming procedure must be performed for only one selector switch setting. For the other selector switch settings, the corresponding DIP switches on the BLPG / BPSG must all be set to 0. Furthermore, the operating mode "Selector switch without BLVT assignment" (FF DD) must be set using the HEX switches on the PLSG after programming.

3.11 Dimensional drawings of the BLPG / BPSG



Bild 18/1

3.12 Technical specifications of the BLPG / BPSG programming unit and controllers

Characteristic data

Safety category	4 according to EN 954-1 and IEC 61496 or EN 61496 (only in conjunction with the BLVT light curtain)
Functions	<ul style="list-style-type: none"> - Programming of 11 BLVT blanking modes - With / without restart interlock (only in conjunction with the BLVT light curtain) - With / without contactor / valve control (only in conjunction with the BLVT light curtain) - Selector switch operation Store and recall up to 5 blanking modes in the BLVT light curtain OR store and recall up to 5 operating modes in the PLSG controller OR store and recall up to 5 operating modes in the PLSG controller AND up to 5 blanking modes in the BLVT light curtain
Response time	BPSG: 6 ms

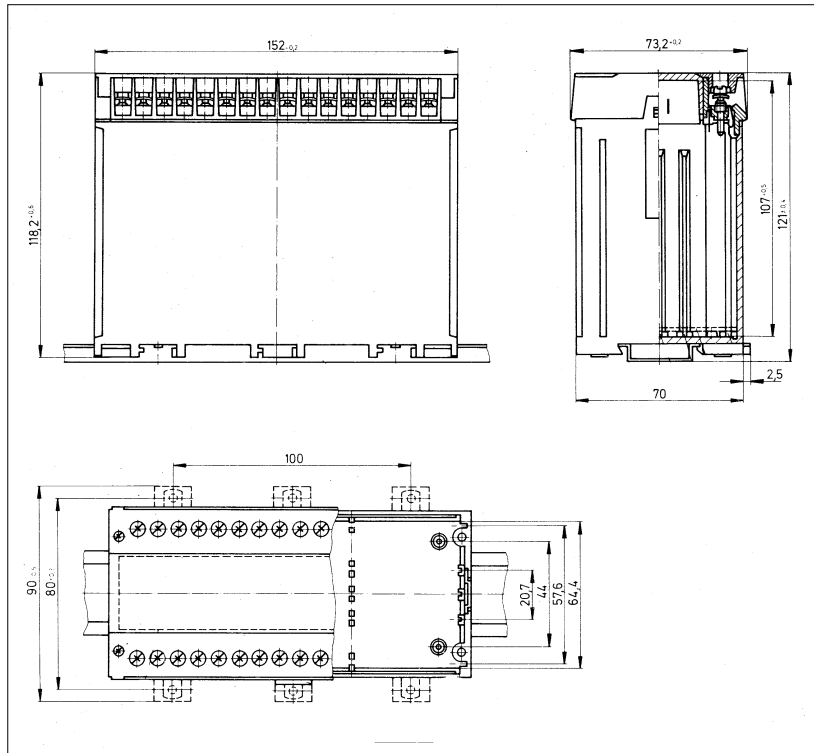
Mechanical data

Housing design	Black insulating material, beige cover
Fastening	Snap-on fastening on a hat rail (DIN EN 50022-35), screw fastening
Weight	BLPG: 800 g; BPSG: 1200 g

Operational data

Protection type	IP 20
Protection class	Protective insulation
Ambient operating temperature	-10 to 55 °C
Storage temperature	-25 to 70 °C

Electrical data

Supply voltage	BLPG: 24 V DC + 20% - 10% BPSG: 230 V AC/50Hz +10% -15%, 115 V AC/50Hz +10% -15% or 24 V DC, + 20% - 10%
Outputs (BPSG)	The output contacts are potential-free, force-guided and normally open with a maximum loading capacity of 2 A/250 V AC or 60 V DC, 30 W.
Inputs	Contact control (SK, EDM-BLVT and EDM-MS) and restart interlock (ST = start button): 0 V to 24 V DC ± 20% (no extraneous voltage!)
Electrical connection	Plug-in terminal strip
Connection cable	Max. 1,5 mm ²

3.13 Notes

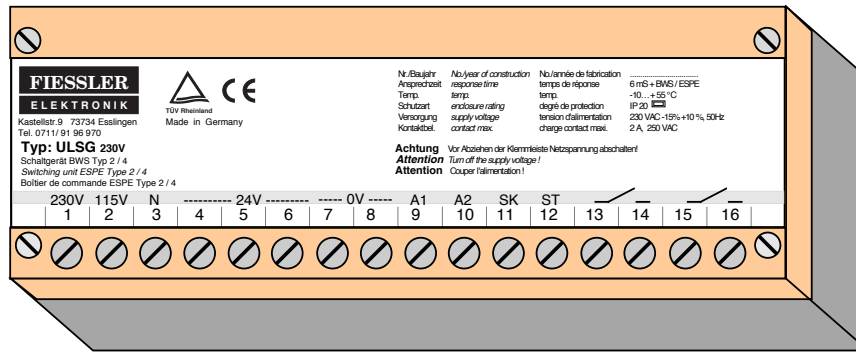

ControllerULSG

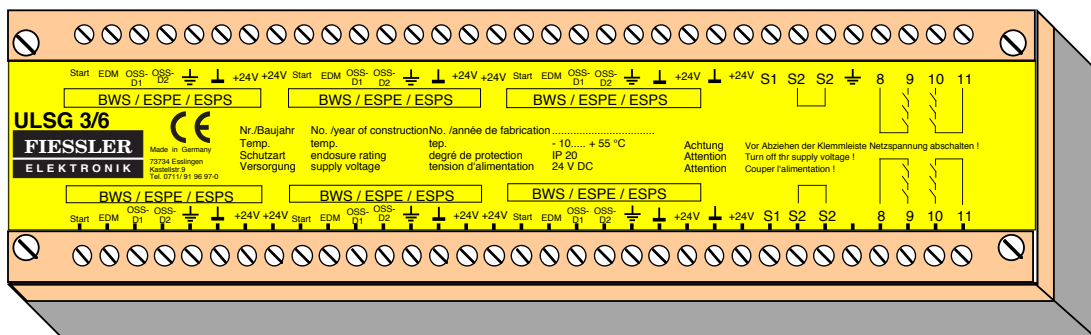

ControllerULSG3/
6

Chapter Contents

Page

4. ULSG / ULSG3/6 controllers

4.1 Connection of ULSG with restart interlock / with contactor control (EDM).....22

4.2 Connection of ULSG with restart interlock / without external contactors23

4.3 Connection of ULSG without restart interlock / without control of subsequent switching elements24

4.4 ULSG 3/6: Connections for up to 6 light curtains (24 V DC)25

4.5 ULSG 3/6: Connection with restart interlock / with contactor control (EDM).....26

4.6 ULSG 3/6: Connection with restart interlock / without control of subsequent switching elements27

4.7 Dimensional drawings 28

4.8 Technical data..... 29

4.9 Notes 30

4.1 Connection of ULSG with restart interlock / with contactor control (EDM)(230 V AC, 115 V AC or 24 V DC connection)

The ULSG fulfils the power-failure bridging standard of 20 ms specified by EN 60204 and is therefore suitable for supplying the ULVT / BLVT light curtains with a voltage.

External contactors control hazardous movement

If the protective field is clear and the start button is operated, potential-free output contacts 13-14 and 15-16 close, and connected contactors K1 and K2 are engaged.

When controlling hazardous movements by means of contactors K1 and K2, connect their NO-contacts in series.

Connection pin 2 (EDM = contactor control) on the light curtain can be used to control the contactor or hydraulic valves K1 and K2 (control path: terminals 4 and 20 on the controller) which initiate the hazardous movement. If the protective field is infiltrated, the output contacts open and movement is interrupted. Operation can only be continued by actuating the start button. However, commencement of a new duty cycle or movement is only possible once both contactors / valves K1 and K2 have been released and the protective field is clear again.

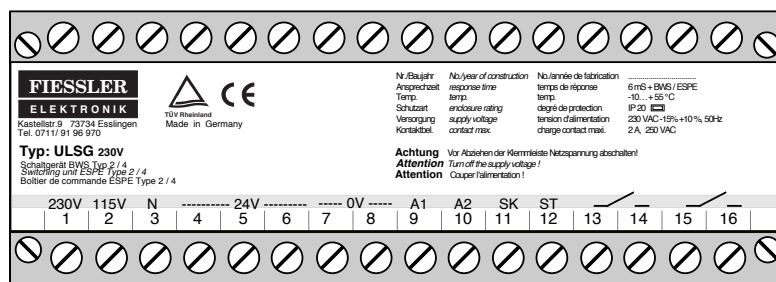

Supply voltage options:

Terminal 1 & 3: 230 V AC -15%+10%
or Terminal 2 & 3: 115 V AC -15%+10% or Terminal 5 & 7: 24 V DC -10%+20%

Spark quenching elements

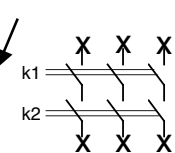

X = To interrupt hazardous movement

To commence closure by contactors K1 and K2, their NO-contacts must be connected in series.

Connection of light curtain ULVT / BLVT: (safety category 4)

Light grid ULVT 500/2R: Like receiver; no transmitter

12 Y 9 10 8 4

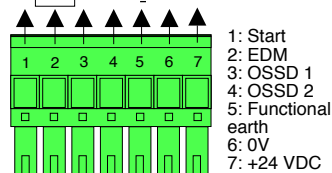

Receiver ULVTE / BLVTE

Set operating mode:
- With contactor control
- With restart interlock
- Synchronized outputs

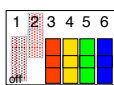

8 5

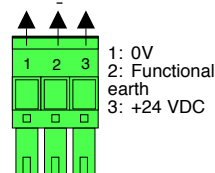

Transmitter ULVTS / BLVTS

Connection of light curtain TLVT / ILVT: (safety category type 2) Important! Only permissible for safety category 2

9 10 12 Y 8 4

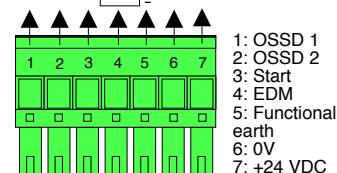

Receiver TLVTE / ILVTE

Set operating mode:
- With contactor control
- With restart interlock
- Synchronized outputs

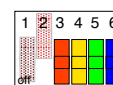

5 8

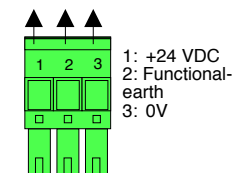

Transmitter TLVTS / ILVTS

Cable installation: Separate from high-voltage lines.

Hazardous movements must only be performed via output contacts 13-14 and 15-16. These contacts are potential-free, force-guided and normally open with a maximum loading capacity of 2 A/250 V AC or 60 V DC, 30 W. If an inductive load is employed, it (not the contacts) must be connected in parallel with spark quenching elements (for

example, 0.22 μ F, 220 Ω).

No extraneous potential must be connected to terminal 9, 10, 11 or 12.

If electric welding needs to be performed on the machine, pull out the controller's terminal strip to prevent stray welding currents from damaging the integrated electronics.



4.3 Connection of ULSG without restart interlock / without control of subsequent switching elements (230 V AC, 115 V AC or 24 V DC connection)

The ULSG controller fulfils the power-failure bridging standard of 20 ms specified by EN 60204 and is therefore suitable for supplying the ULVT / BLVT light curtains with a voltage.

If the protective field is infiltrated, output contacts 13 - 14 and 15 – 16 open. If the protective field is cleared, the output contacts close.

Connection pin 2 (EDM = contactor control) on the light curtain can be used to additionally control the internal switching elements (13 - 14 and 15 - 16) which initiate hazardous motion.



The connected, safeguarded control system must monitor the subsequent switching elements and possess a restart interlock depending on the application involved.

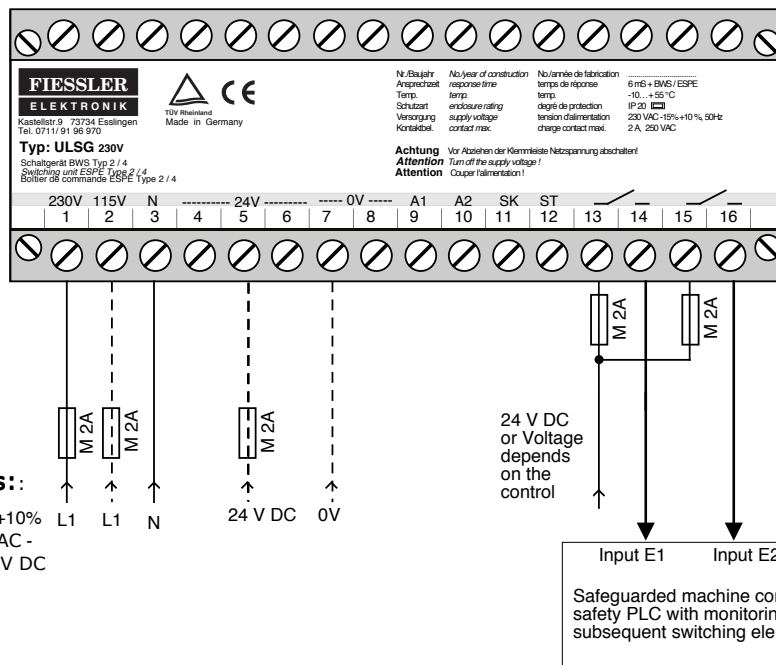

Supply voltage options:

Terminal 1 & 3: 230 V AC -15%+10%
 or Terminal 2 & 3: 115 V AC -15%+10%
 or Terminal 5 & 7: 24 V DC -10%+20%

Connection of light curtain ULVT / BLVT (safety category 4):

receiver; no transmitter

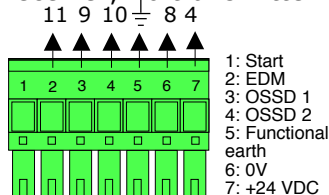

Receiver ULVTE / BLVTE

Set operating mode:
 - With contactor control
 - ohne Wiederanlaufsperr
 - Synchronized outputs

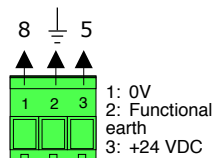
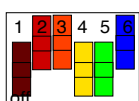

Transmitter ULVTS / BLVTS

Connection of light curtain TLVT / ILVT (safety category 2): Important! Only permissible for safety category 2

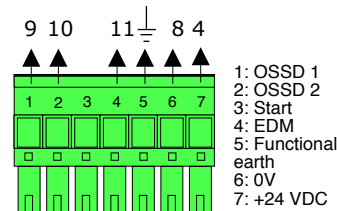

Receiver ULVTE / BLVTE

Set operating mode:
 - With contactor control
 - ohne Wiederanlaufsperr
 - Synchronized outputs

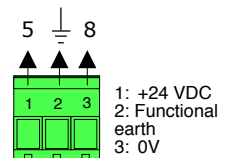
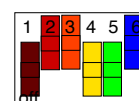

Transmitter TLVTS / ILVTS

Cable installation: Separate from high-voltage lines.

Hazardous movements must only be performed via output contacts 13-14 and 15-16. These contacts are potential-free, force-guided and normally open with a maximum loading capacity of 2 A/250 V AC or 60 V DC, 30 W. If an inductive load is employed, it (not the contacts) must be connected in parallel with spark quenching elements (for

example, 0.22 μF, 220 Ω). No extraneous potential must be connected to terminal 9, 10, 11 or 12.

If electric welding needs to be performed on the machine, pull out the controller's terminal strip to prevent stray welding currents from damaging the integrated electronics.

4.4 Connection of up to 6 ULVT / BLVT safety light grids to ULSG 3/6 (only for 24 V DC connection)

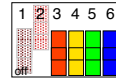

Receiver ULVTE / BLVT

- Set operating mode:
- With contactor control
 - With restart interlock
 - Synchronized outputs

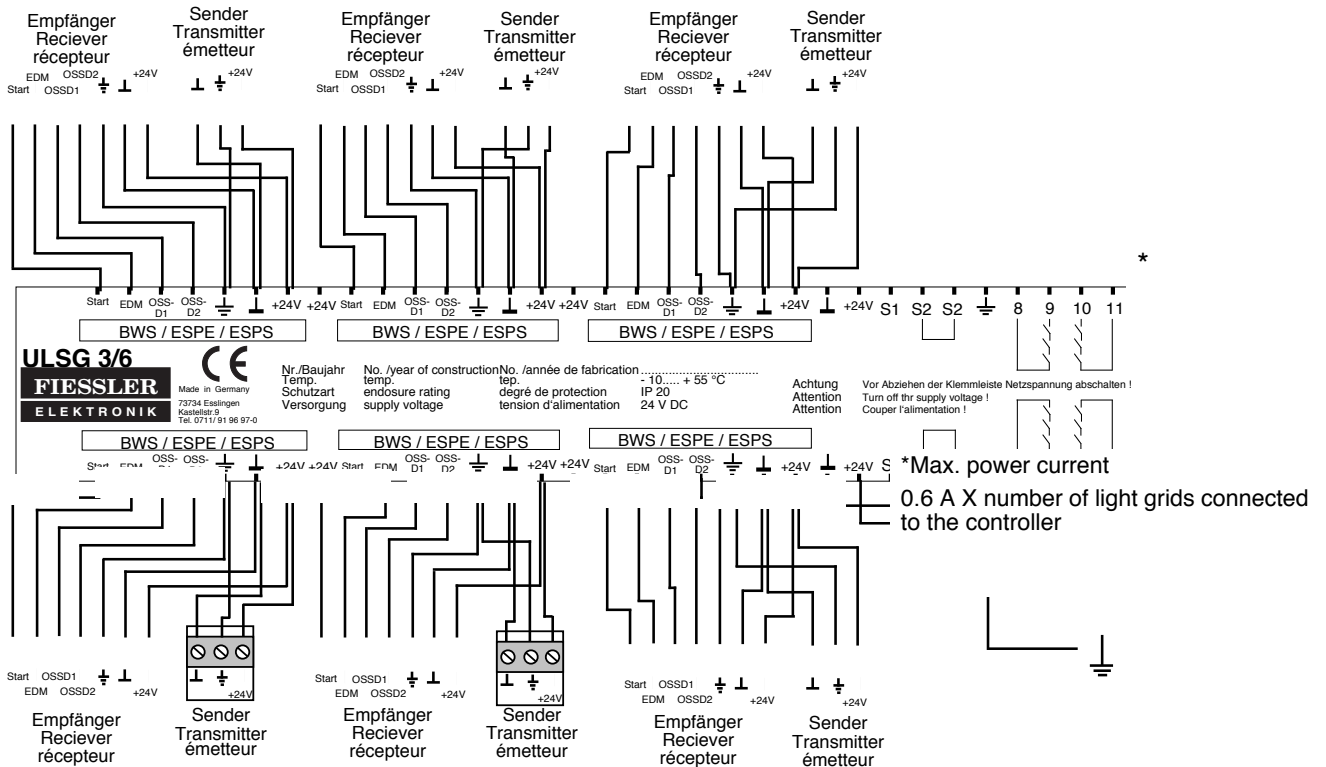

Important note !!!

If not all 3 or 6 light grids are connected, +24 V must be applied to the free OSSD1 and OSSD2.

4.5 Connection of ULSG 3/6 with restart interlock / with contactor control

Application examples

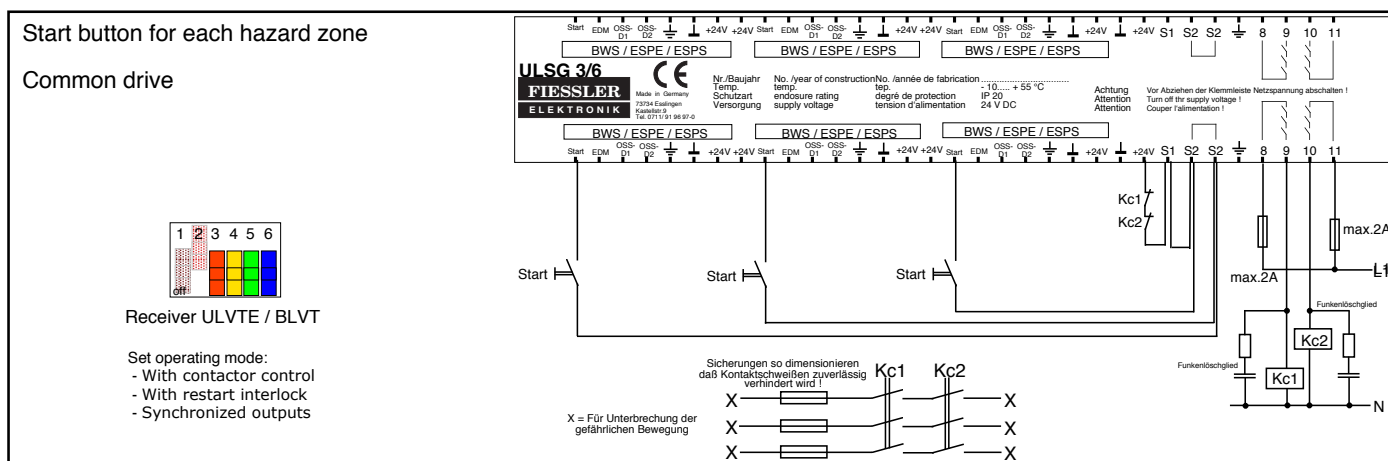
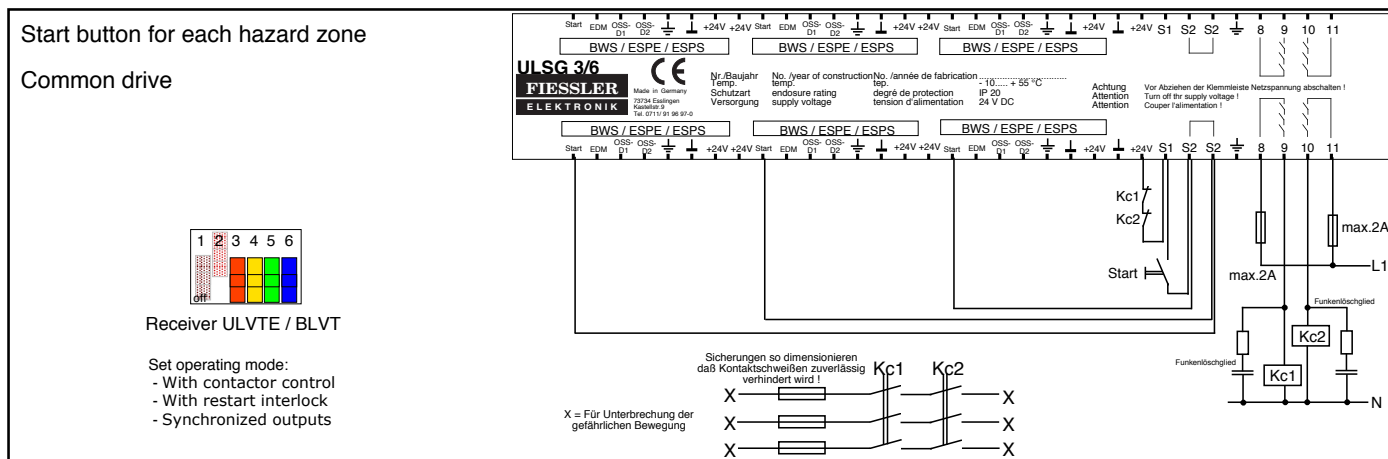

If 6 light grids are employed, they are to be connected via the top and bottom terminals. Output contacts 8 - 9 and 10 - 11 of the upper terminal side are separated from output contacts 8 - 9 and 10 - 11 of the lower terminal side. These can be connected in series if necessary: 8 - 9 (top) in series with 8 - 9 (bottom), 10 - 11 (top) in series with 10 - 11 (bottom)

If not all 3 or 6 light barriers are connected, +24 V must be applied to the free OSSD1 and OSSD2.

4.7 Dimensional drawings of ULSG / ULSG

ULSG:

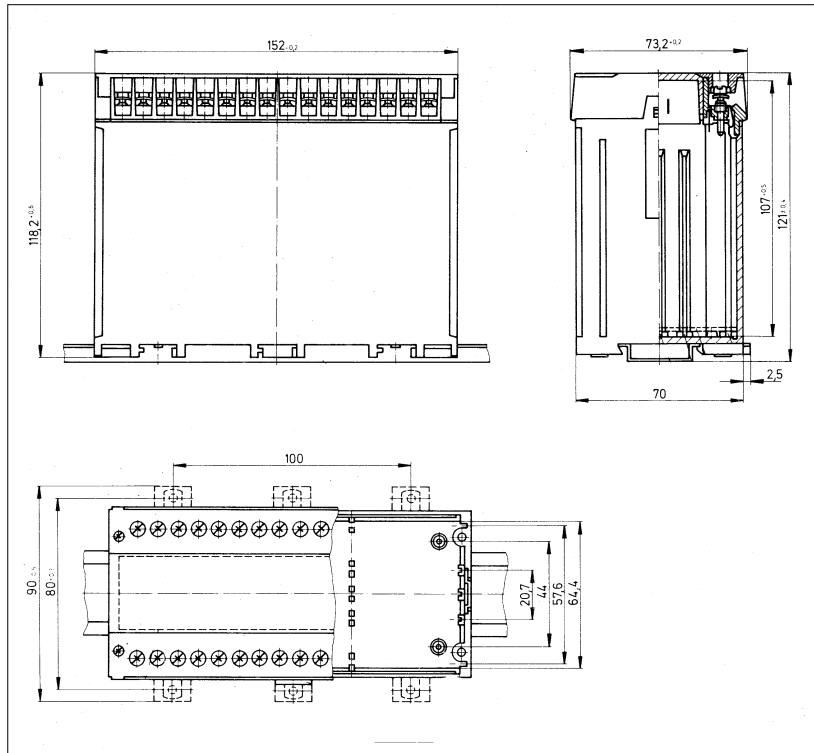

ULSG 3/6:

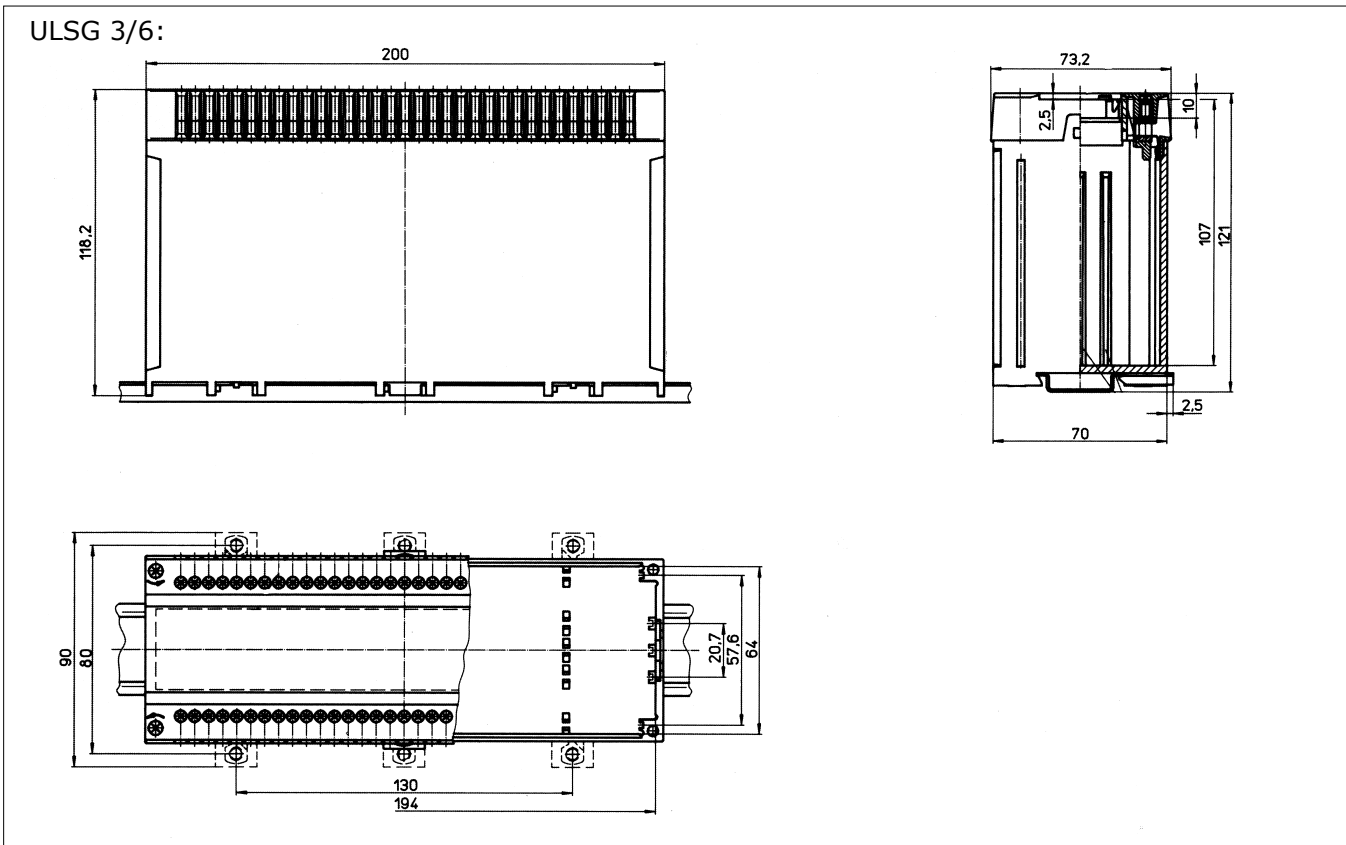

4.8 Technical specifications of the ULSG / ULSG3/6 controllers

Characteristic data

Safety category	4 according to EN 954-1 and IEC 61496 or EN 61496
Operating modes	- With / without restart interlock (only in conjunction with ULVT / BLVT light curtains) - With / without contactor / valve control (only in conjunction with ULVT / BLVT light curtains)
Response time	

Mechanical data

Housing design	Black insulating material, beige cover
Fastening	Snap-on fastening on a hat rail (DIN EN 50022-35), screw fastening
Weight	ULSG: 1200 g, ULSG3/6: g

Operational data

Protection type	IP 20
Protection class	Protective insulation
Ambient operating temperature	-10 to 55 °C
Storage temperature	-25 to 70 °C

Electrical data

Supply voltage	ULSG: 230 V AC/50Hz +10% -15%, 115 V AC/50Hz +10% -15%, or 24 V DC, +20% - 10% ULSG3/6: 24 V DC, +20% - 10%
Outputs	The output contacts are potential-free, monitored (only in conjunction with ULVT / BLVT), force-guided and normally open with a maximum loading capacity of 2 A/250 V AC or 60 V DC, 30 W
Inputs	Contact control and start button: 0 V to 24 V DC ±20% (no extraneous voltage!)
Electrical connection	Plug-in terminal strip
Connection cable	Max. 1,5 mm ²

4.9 Notes

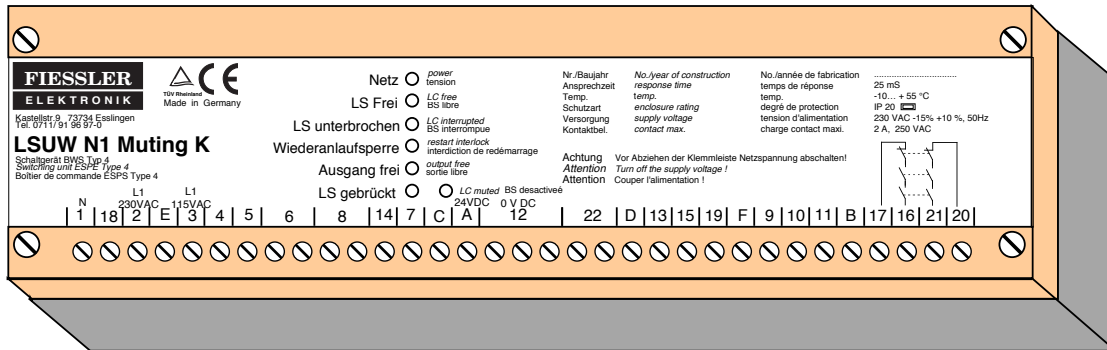

Chapter Contents

Page

5. LSUW N1 Muting K controller

PLSG device family (muting controllers for fitting on the ULVT / BLVT light curtains)	32
5.1 Muting in general (bypass)	33-
Muting sensors	33-
Prevention of muting manipulation	33
5.2 Muting function with time monitoring	- Connection of muting sensors
5.3 Muting function without time monitoring	- Connection of muting sensors
5.4 Connection to 230 VAC/115VAC supply voltage	- Muting lamp / contactor / safety light barrier
5.5 Connection to 24 VDC supply voltage	- Muting lamp / contactor / safety light barrier
5.6 Dimensional drawings	38
5.7 Technical specifications	39
5.8 Notes	40

PLSG device family

For muting, cyclical mode, BLVT programming etc., the PLSG controller family is also available for ULVT / BLVT safety light curtains.



ULVT
or
BLVT

PLSG...

(separate
operating
manual)

Safety controller	PLSG1 Muting safety controller	PLSG2 ^M uting safety controller	PLSG3 ^{Uni} versal controller
Additional functions			
Muting (brief bypass of the light curtain)	●	●	●
Cyclical operation Protective and control functions during cyclical entry into the protective field, for instance,			1-cycle, 2-cycle, 3-cycle or 4-cycle operation
Potential-free switching contacts			
Selector switch operation Changeover between PLSG operating modes and / or BLVT blanking modes			In conjunction with BLPG or BPSG
Connection for 2 to 6 light curtains			
Restart interlock only during working motion			●
BLVT blanking functions Programming of 11 blanking modes			●
Emergency-stop circuit - Connection and monitoring			●
Two-hand start switch - Connection and monitoring			●
Override after irregular stop	●	●	●
Connection voltage	24 VDC	24 VDC	24 VDC
Profile housing mountable on a light grid (only ULVT and BLVT)	●	●	●
Display 2 x 8 LCD characters		●	●

We will be pleased to advise you individually on muting functions for your applications. The applications described here serve purely as examples.

5.1 Muting for example, when safeguarding bending machines, palleting machines, narrow-aisle storage facilities, certain press types. Muting means bypass of a safety light barrier for a certain period of time if this is required by the working cycle, e.g. during material conveyance to or from a production cell (Figure 33/1), or for dependable differentiation between humans and forklifts (Figure 33/2).

Muting is permissible only if the hazard zone remains inaccessible during interruption or no hazardous movement is involved. For this purpose, the space between the material and safety light barrier must be small enough to prevent access to the hazard zone.

Muting sensors

Reliable differentiation between material (for example, conveyed material) and humans or detection of non-hazardous movement is realized by at least 2 mutually independent muting sensors. These can comprise light barriers (for example, GR or MFL series from Fessler-Elektronik), inductive sensors, cam switches or limit switches.

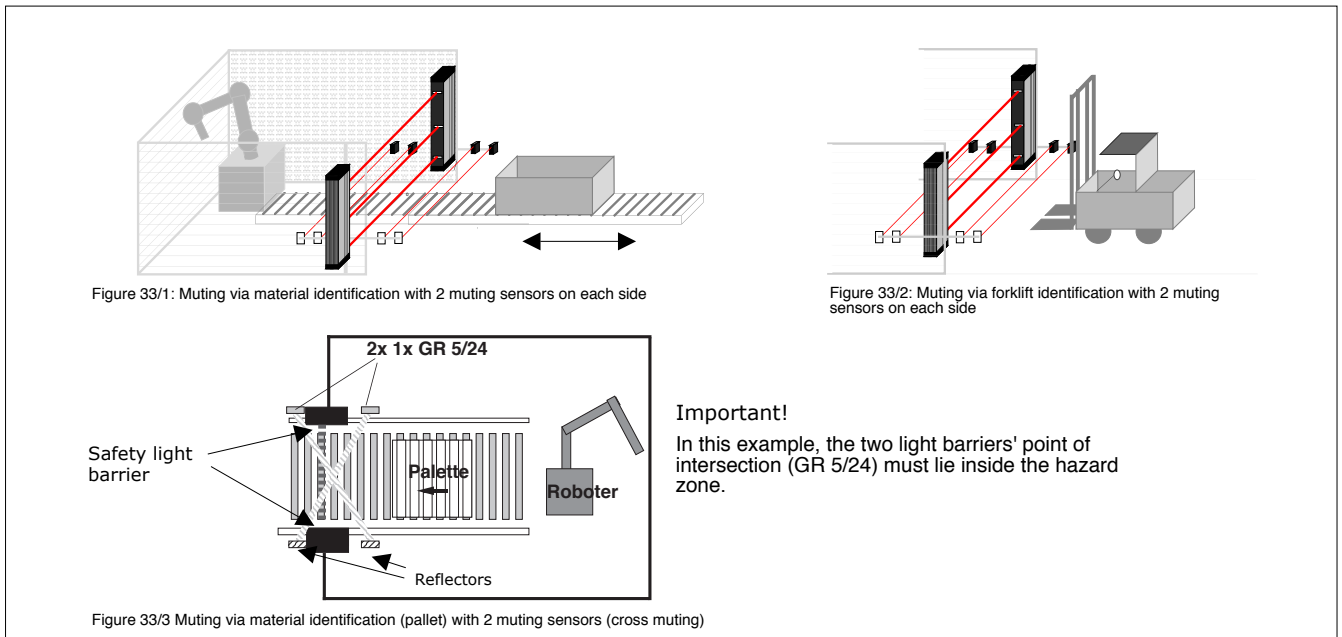

Prevention of muting manipulation through proper assembly The muting sensors must be installed so that the beams of the sensor pairs LS1A-2A, LS1B-2B of relevance to muting cannot be interrupted simultaneously by humans. The distance S must be large enough to prevent simultaneous interruption of the LS 1A / LS 2A and LS 1B / LS 2B muting sensors by humans (Figure 33/3 and Figure 9/4). If necessary, the clearance H to the passable area or the distance S should be increased. For proper bypass, however, the distance S (Figure 33/2) must be smaller than or equal to the length of the pallet, forklift or reflector strip on the transport vehicle.

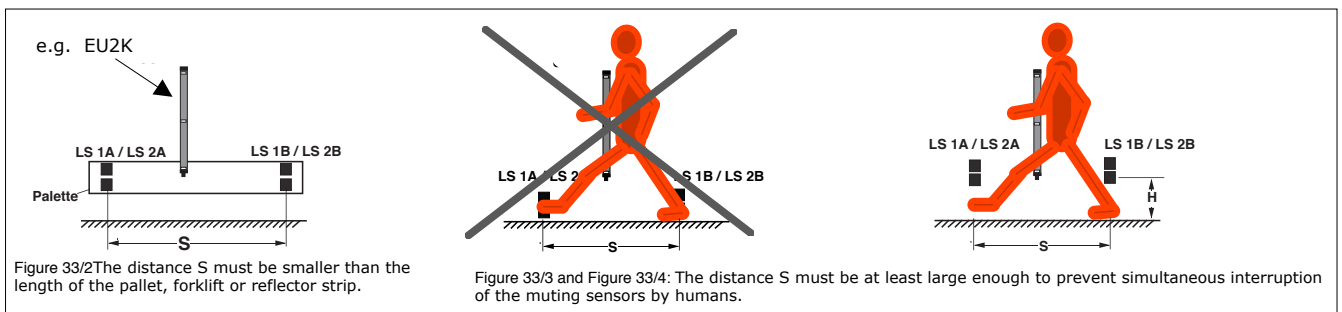

Additional prevention of muting manipulation through muting time limitation (monitoring)

To prevent a safety light curtain from being continuously interrupted by intentional manipulation, a two-channel time monitor is available for disabling the muting function after 3 - 90 seconds. This time can be set by the customer via two potentiometers located behind the front panel (left-hand stop = more time, right-hand stop = less time). The default setting is 90 seconds. Switchover to operation without time monitoring is also possible.

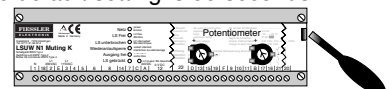

We will be pleased to advise you individually on muting functions for your applications. The applications described here serve purely as examples.

5.2 Muting function with time monitoring (with 2 or 4 muting sensors)

Muting (bypass) The safety light curtain remains bypassed as long as the contacts of muting sensors LS 1A and LS 2A or muting sensors LS 1B and LS 2B or all four are open, but for no longer than the set time.

Stop / alarm If the safety light curtain is interrupted and not bypassed by muting, an alarm is activated via contact B-11 (potential-free, normally closed) and the system is deactivated via output contacts 20-21 and 16-17.

Restart interlock Restart and alarm deactivation are performed by actuating the start button with the safety light curtain clear.

For applications in which hazardous movements cannot be interrupted (e.g. vehicles) but only an alarm is output



Before actuating the start button, ensure that nobody is present in the danger zone. This button must be positioned such that the safeguarded area remains visible.

instead, a key switch must be employed as the start button. Removal of the key should only be possible in the open state. The alarm is activated on connection of the system to the mains voltage. It can be deactivated again by turning the start key

switch.

Override function (dead-man circuit). This function permits restart after an irregular stop in the muted state. Restart is only possible if the safety light curtain and the muting sensors are free; if this condition is prevented, e.g. by a blocked pallet, an authorized operator can use a key switch to release the pallet so that the safety light curtain and muting sensors are cleared.

Contactor / valve control (EDM) Before every release of a switching output, a check is made as to whether the connected switching elements are also released, i.e. whether their force-guided auxiliary NC contacts are closed; only under these circumstances can the outputs be enabled again.

Muting lamp The muting lamp indicating the bypass state is monitored. Bypass is not possible if this lamp is disconnected or defective. (Muting lamp: 230/115V 60 W; or 24 V AC/DC min. 50 mA, Max. 0.5 A)

Example with 4 muting sensors:

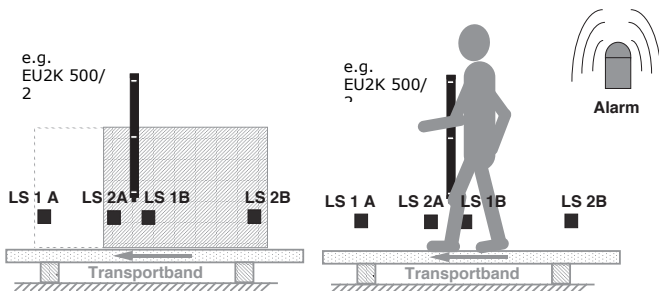

Example with 2 muting sensors (e.g. cross-muting):

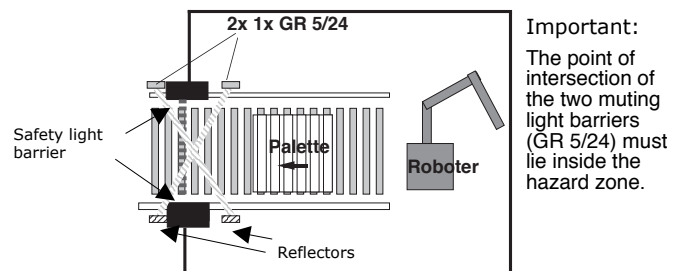

Connection of muting sensors

Connection of 4 muting sensors with time monitoring:

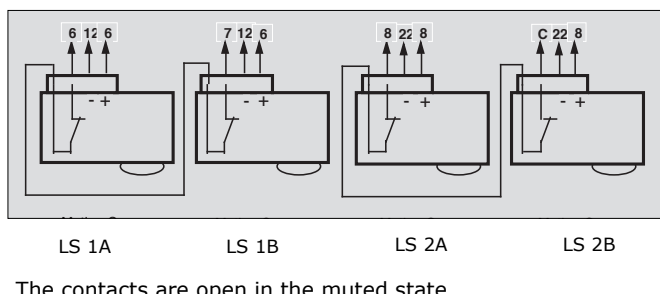

Connection of 2 muting sensors with time monitoring: (e.g. cross-muting)

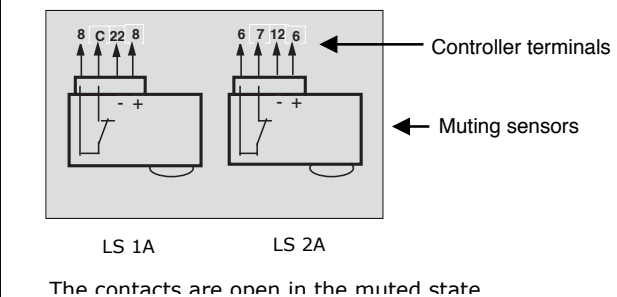

Cable installation The cabling between the light curtain and LSUW N1 Muting K must be designed to isolate 250 V and installed separately from high-voltage lines. The cabling for contactor control (terminals D & 22) must be installed so as to preclude a short-circuiting of conductors. For safety reasons, minus and plus lines must be installed as shown in the connection diagram. Cables for the muting channels (LS1A/1B) and (LS 2A/2B) must be installed separately.



Hazardous movement must only be initiated via output contacts 16-17 and 20-21. Contact B-11 serves as an alarm channel and is not permissible for initiating hazardous closure.

The output contacts are potential-free, monitored, force-guided, and normally open with a maximum loading capacity of 2 A/250 V AC or 60 V DC, 30 W. If an inductive load is employed, it (not the contacts) must be connected in parallel with spark quenching elements (for example, 0.22 µF, 220 Ω). If the sum of the currents through terminals B, 10, 17 and 21 exceeds 2A, each contact must be protected by M 2.0 A.

If electric welding needs to be performed on the machine, pull out the controller's terminal strip to prevent stray welding currents from damaging the integrated electronics.

5.3 Muting function without time monitoring (with 2 or 4 muting sensors)

For example, for safeguarding high racks in warehouses where conveyance vehicles can be parked in the entrance zone.

Muting (bypass) Bypass remains active as long as the contacts of muting sensors LS 1A and LS 2A or muting sensors LS 1B and LS 2B or all four are closed.

Stop / alarm If the safety light curtain is interrupted and not bypassed by muting, an alarm is activated via contact B-11 (potential-free, normally closed) and the system is deactivated via output contacts 20-21 and 16-17.

Restart interlock Restart and alarm deactivation are performed by actuating the start button with the safety light curtain clear.

For applications in which hazardous movements cannot be interrupted (e.g. vehicles) but only an alarm is output instead, a



Before actuating the start button, ensure that nobody is present in the danger zone. This button must be positioned such that the safeguarded area remains visible.

key switch must be employed as the start button. Removal of the key should only be possible in the open state. The alarm is activated on connection of the system to the mains voltage. It can be deactivated again by turning the start key switch.

Override function (dead-man circuit). This function permits restart after an irregular stop in the muted state. Restart is only possible if the safety light curtain and the muting sensors are free; if this condition is prevented, e.g. by a blocked pallet, an authorized operator can use a key switch to release the pallet so that the safety light curtain and muting sensors are cleared.

Contactor / valve control (EDM) Before every release of a switching output, a check is made as to whether the connected switching elements are also released, i.e. whether their force-guided auxiliary NC contacts are closed; only under these circumstances can the outputs be enabled again.

Muting lamp The muting lamp indicating the bypass state is monitored. Bypass is not possible if this lamp is disconnected or defective. (Muting lamp: 230/115V 60 W; or 24 V AC/DC min. 50 mA, Max. 0.5 A)

An especially high degree of protection against manipulation can be achieved, for instance, by means of GR or MFL reflex light barriers from Fessler Elektronik.

In this configuration, the reflex light barriers are connected in bright-switching mode.

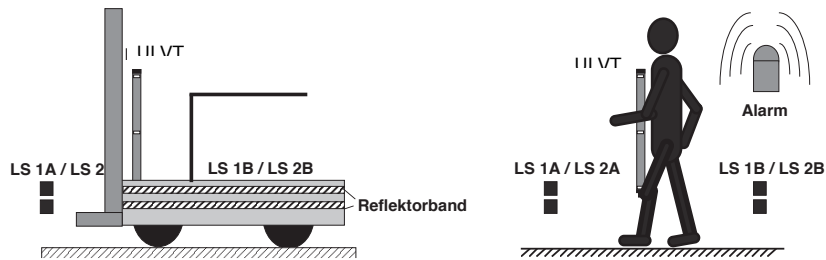

Connection of muting sensors

Connection of 4 muting sensors without time monitoring:

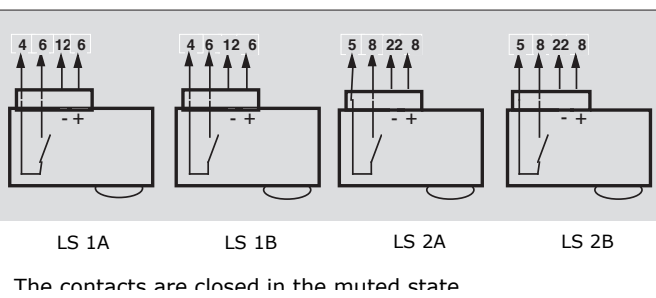

Connection of 2 muting sensors without time monitoring: (for example, cross-muting)

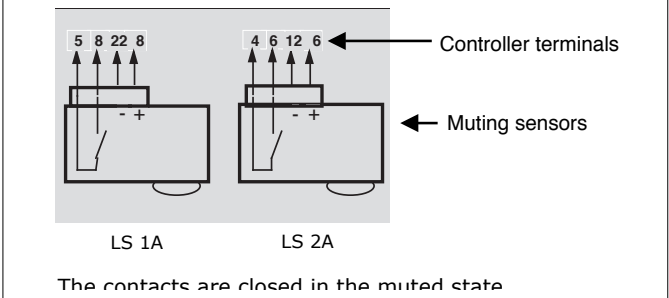

Cable installation The cabling between the light curtain and LSUW N1 Muting K must be designed to isolate 250 V and installed separately from high-voltage lines. The cabling for contactor control (terminals D & 22) must be installed so as to preclude a short-circuiting of conductors. For safety reasons, minus and plus lines must be installed as shown in the connection diagram. Cables for the muting channels (LS1A/1B) and (LS 2A/2B) must be installed separately.

 Hazardous movement must only be initiated via output contacts 16-17 and 20-21. Contact B-11 serves as an alarm channel and is not permissible for initiating hazardous closure.

The output contacts are potential-free, monitored, force-guided, and normally open with a maximum loading capacity of 2 A/250 V AC or 60 V DC, 30 W. If an inductive load is employed, it (not the contacts) must be connected in parallel with spark quenching elements (for example, 0.22 µF, 220 Ω). If the sum of the currents through terminals B, 10, 17 and 21 exceeds 2A, each contact must be protected by M 2.0 A.

If electric welding needs to be performed on the machine, pull out the controller's terminal strip to prevent stray welding currents from damaging the integrated electronics.

5.4 Connection to a 230 VAC or 115 VAC voltage supply Muting lamp / contactors / safety light barrier

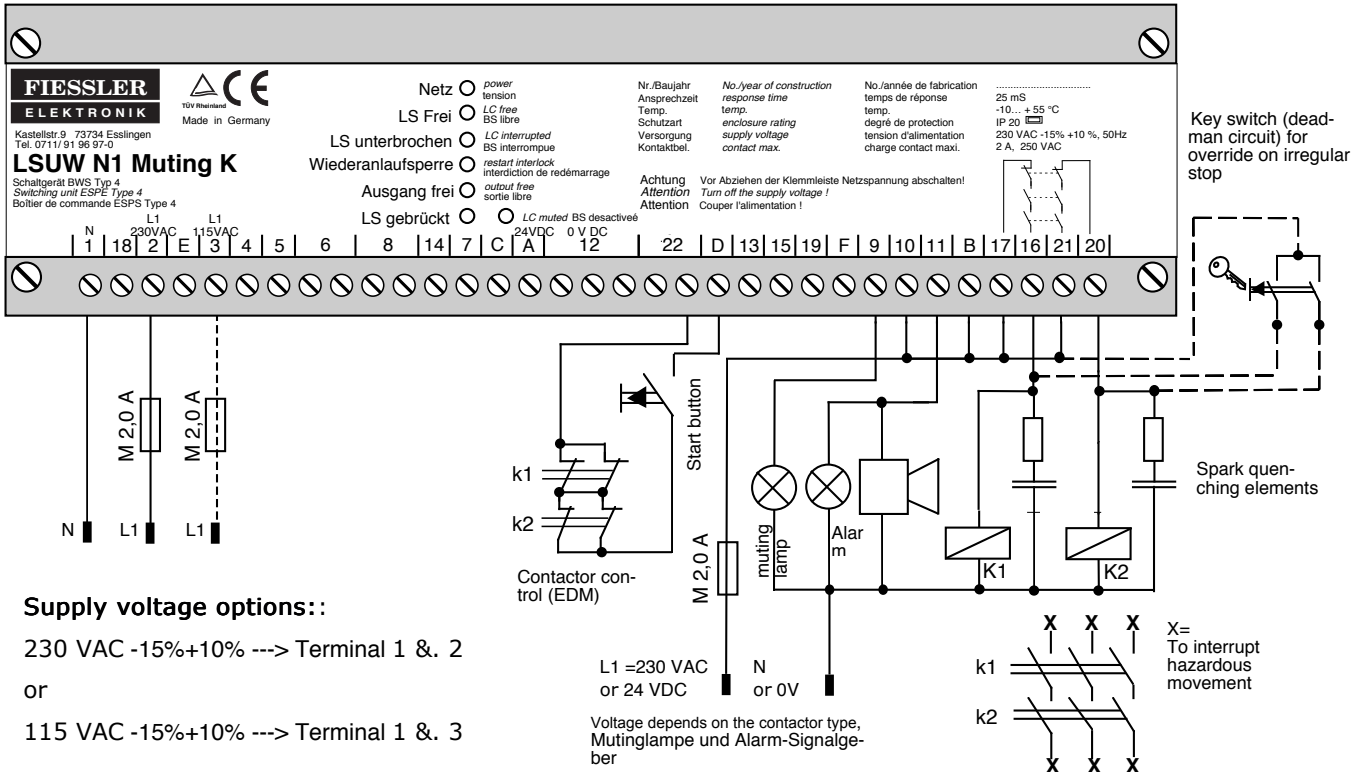

<p>Connection of LSUW light curtain:</p> <p>Transmitter = 230 VAC version</p> <p>Bridge required: F - E</p> <p>Transmitter = 24 VDC (special) version</p> <p>Bridge required: F - 14</p>	<p>Connection of EU2K light barrier:</p> <p>Transmitter = 230 VAC version</p> <p>Bridge required: F - E</p> <p>Transmitter = 24 VDC version</p> <p>Bridge required: F - 14</p>	<p>Connection of EU2K 500/2 light curtain:</p> <p>Transmitter = 230 VAC version</p> <p>Bridge required: F - E</p> <p>Transmitter = 24 VDC version</p>
<p>Connection of ULVT / BLVT light curtain (safety category 4): Connection of a ULVT 500/2R light grid is not possible</p> <p>Receiver ULVTE / BLVTE</p> <p>Set operating mode: -Without contactor control -Without restart interlock (both functions are performed by the controller) -Non-equivalent outputs</p> <p>Transmitter ULVTS / BLVTS</p> <p>Bridge required: F - 14</p>	<p>Connection of TLVT / ILVT light curtain (safety category 2): Important: Only permissible for applications in safety category 2!</p> <p>Receiver TLVTE / ILVTE</p> <p>Set operating mode: -Without contactor control -Without restart interlock (both functions are performed by the controller) -Non-equivalent outputs</p> <p>Transmitter TLVTS / ILVTS</p> <p>Bridge required: F - 14</p>	

5.5 Connection to 24 VDC voltage supply Muting lamp / contactors / safety light barrier

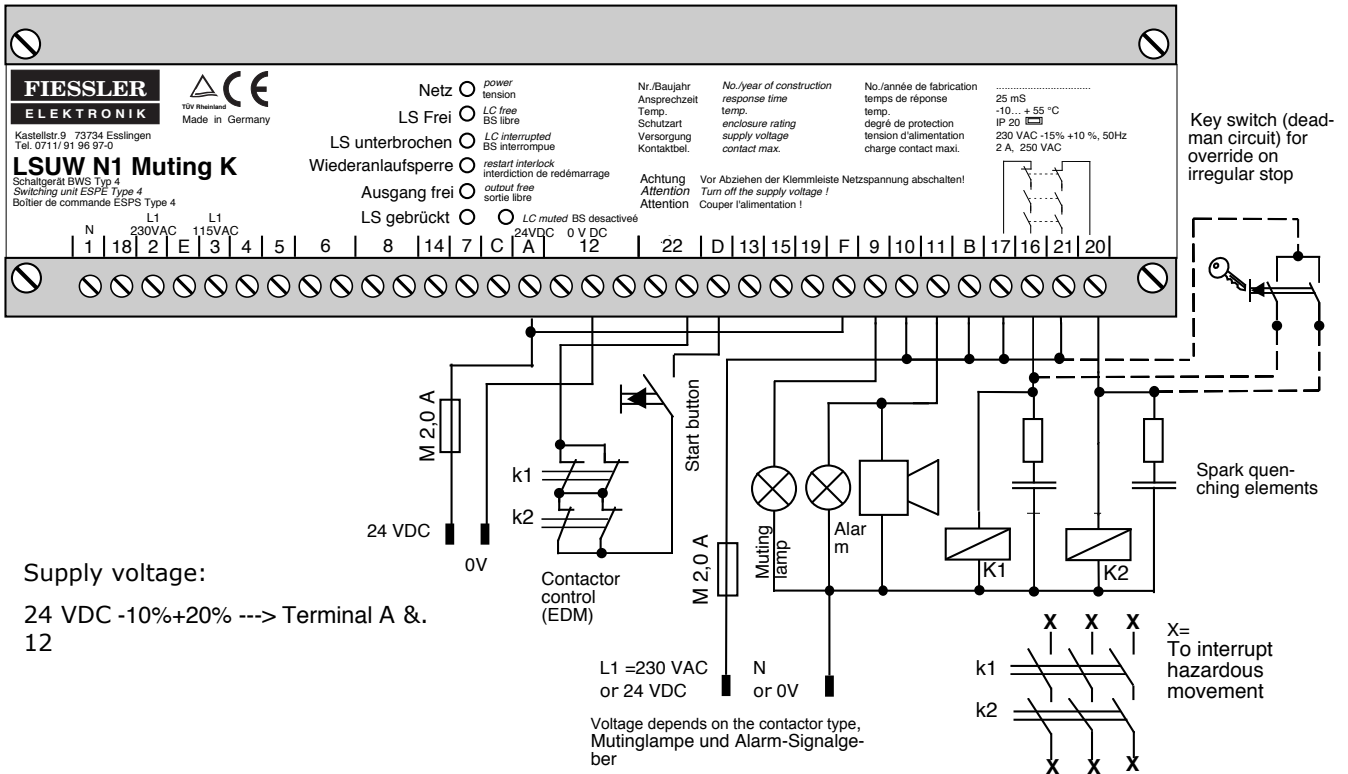

Connection of LSUW light curtain

Transmitter = 24 VDC version

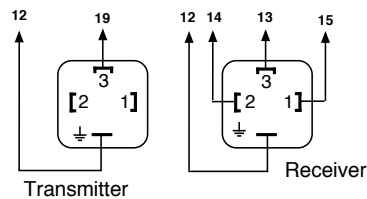

Connection of EU2K light barrier

Transmitter = 24 VDC version

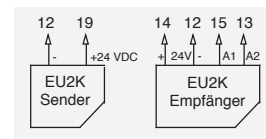

Connection of EU2K 500/2 light curtain

Transmitter = 24 VDC version

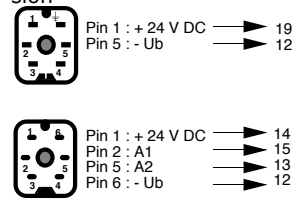

Connection of ULVT / BLVT light curtain (safety category 4): Connection of ULVT 500/2R light grid is not possible

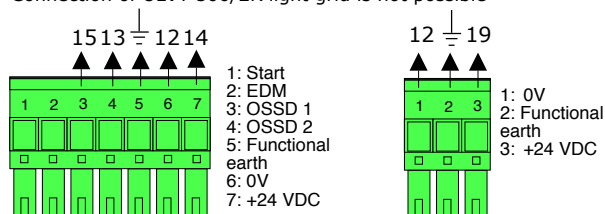

Receiver ULVTE / BLVTE

Set operating mode:
-Without contactor control
-Without restart interlock (both functions are performed by the controller)
-Non-equivalent outputs

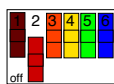

Connection of TLVT / ILVT light curtain (safety category 2): Important: Only permissible for applications in safety category 2

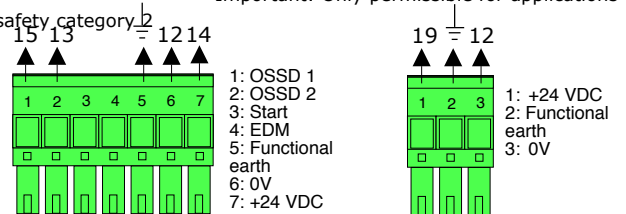

Receiver TLVTE / ILVTE

Set operating mode:
-Without contactor control
-Without restart interlock (both functions are performed by the controller)
-Non-equivalent outputs

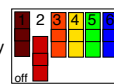

5.6 Dimensional drawings of LSUW N1 Muting K

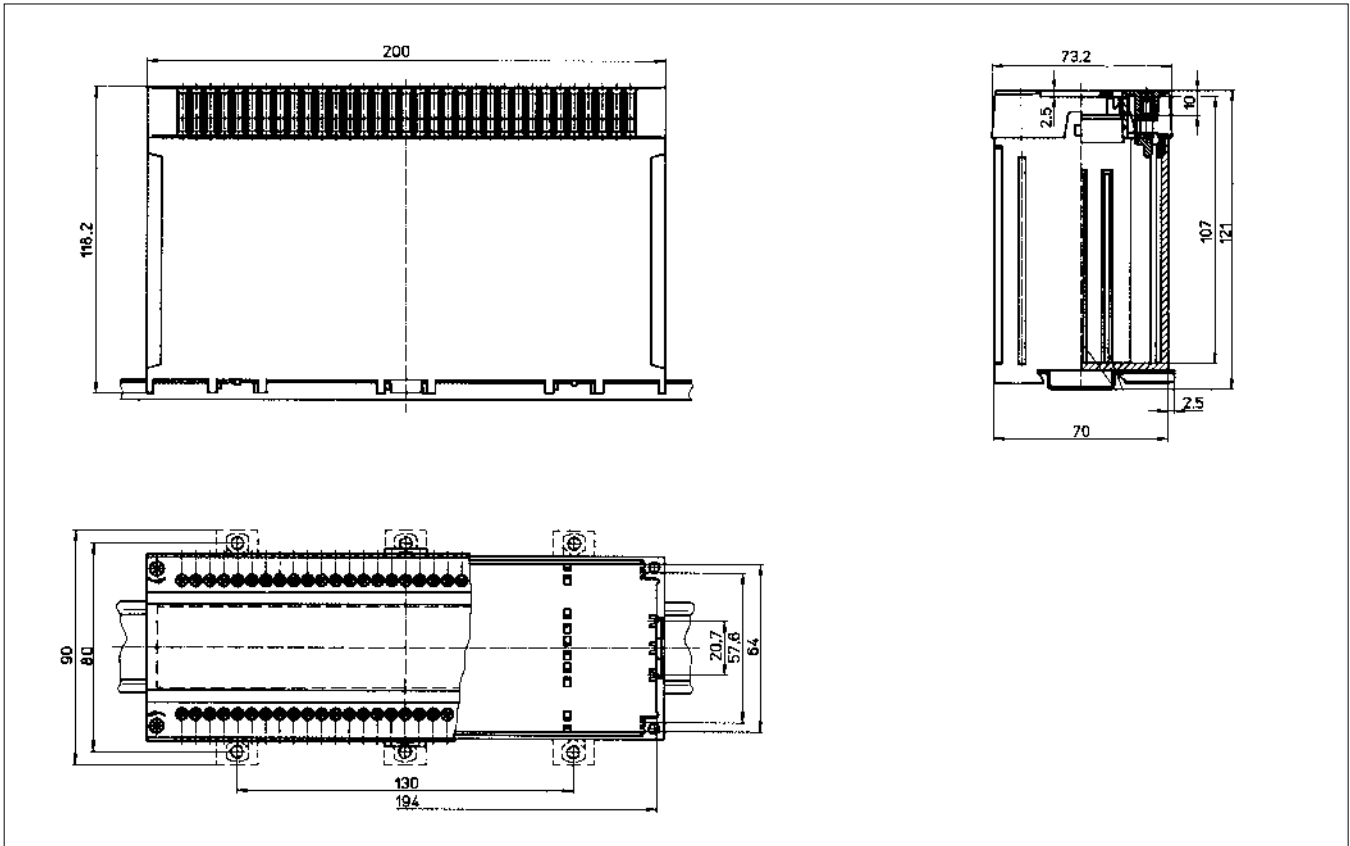

5.7 Technical specifications of LSUW N1 Muting K

Characteristic data

Safety category	4 according to EN 954-1 and IEC 61496 or EN 61496
Functions	<ul style="list-style-type: none"> - Muting (with muting sensors) - Restart interlock - Contactor / valve control
Response time	20 ms + response time of light curtain/light barrier

Mechanical data

Housing design	Black insulating material, beige cover
Fastening	Snap-on fastening on a hat rail (DIN EN 50022-35), screw fastening
Weight	1700 g

Operational data

Protection type	IP 20
Protection class	Protective insulation
Ambient operating temperature	-10 to 55 °C
Storage temperature	-25 to 70 °C

Electrical data

Supply voltage	230 V AC/50Hz +10% -15%, 115 V AC/50Hz +10% -15% or 24 V DC, + 20% - 10%, protected against reverse polarity
Outputs	The output contacts are potential-free, monitored, force-guided and normally open with a maximum loading capacity of 2 A/250 V AC or 60 V DC, 30 W.
Electrical connection	Plug-in terminal strip
Connection cable	Max. 1,5 mm ²

5.8 Notes

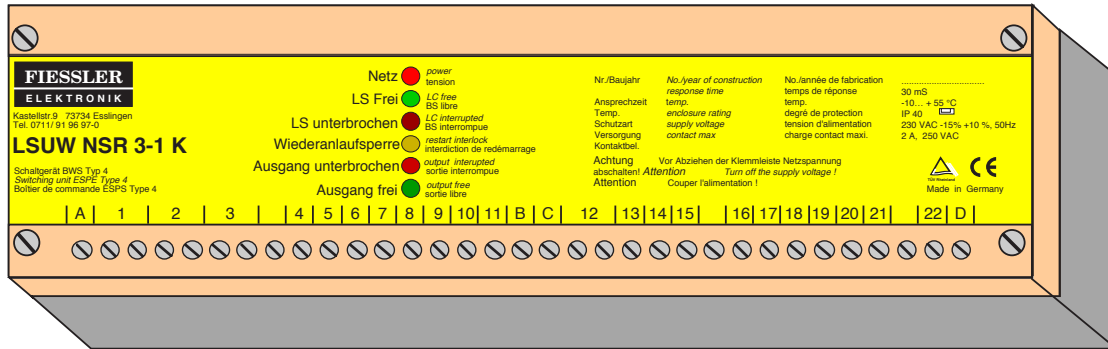

Chapter Contents

Page

6.	LSUW NSR 3-1 K controller	
6.1	Connections for all operating modes	42
6.2	"A" cyclic mode (control via cyclic infiltration of the protective field)	43
6.3	"B" protective mode with restart interlock	44
6.4	"AB" changeover mode (between cyclic and protective mode with restart interlock)	45
6.5	"B1" protective mode with restart interlock (only during hazardous motion)	46
6.6	"C" protective mode without restart interlock / valve or contactor control	47
6.7	"D" protective mode with restart interlock and cyclic test (only for LSUW light curtain)	48
6.8	Dimensional drawings	49
6.9	Technical data	50
6.10	Notes	51

6.1 Connections for all operating modes

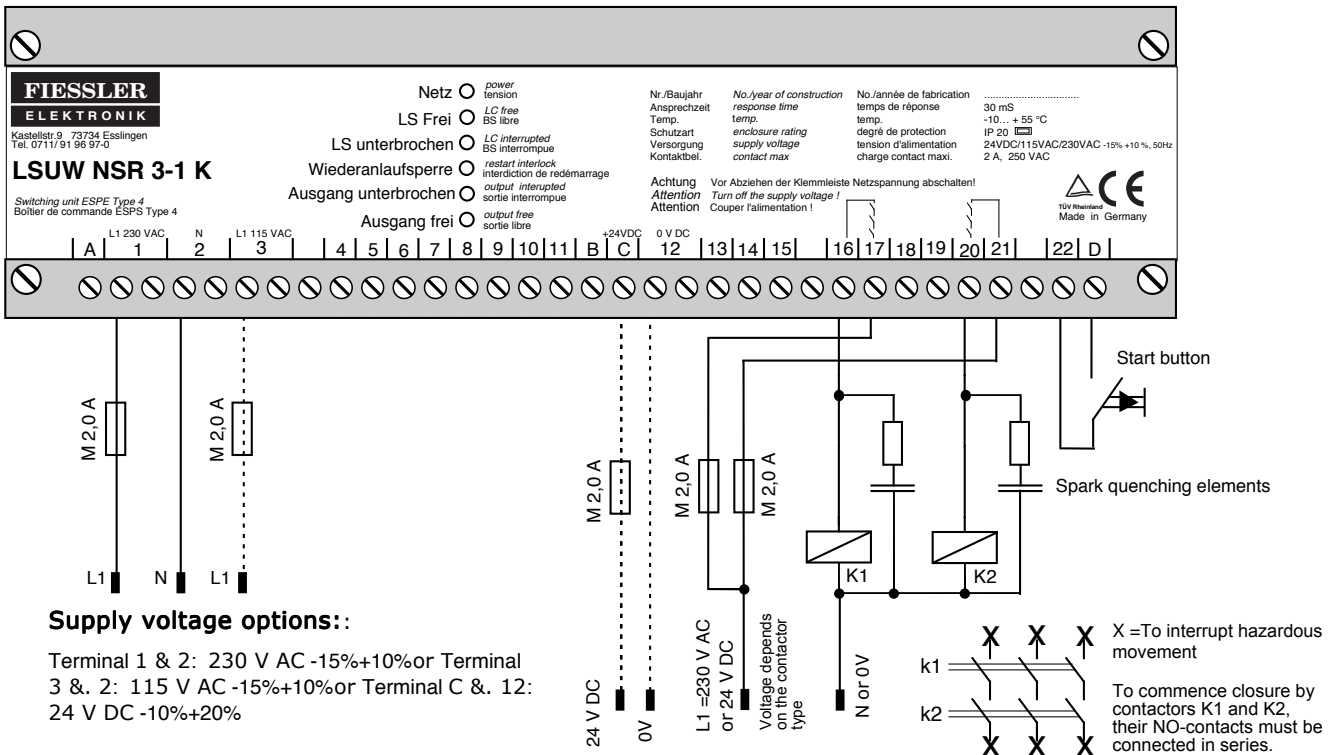

Connection of LSUW light curtain:

Transmitter = 230 VAC version

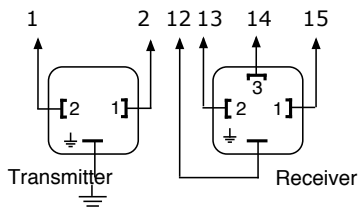

Transmitter = 24 VDC (special) version

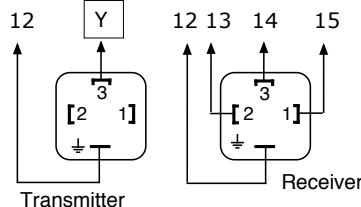

Connection of ULVT or BLVT light curtain

Set operating mode:
-Without contactor control
-Without restart interlock (both functions are performed by the controller)
-Non-equivalent outputs

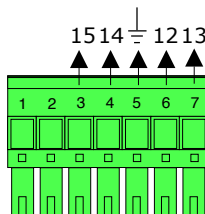
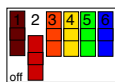

1: Start
2: EDM
3: OSSD 1
4: OSSD 2
5: Functional earth
6: 0V
7: +24 VDC

Receiver ULVTE / BLVTE

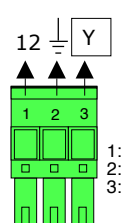

1: 0V
2: Functional earth
3: +24 VDC

Transmitter ULVTS / BLVTS

In case of 230 V AC / 115 V AC
Terminal 13
Bei 24 V DC : Terminal C



The cabling between the light curtain and LSUW NSR 3-1 K must be designed to isolate 250 V and installed separately from high-voltage lines. The cabling for contactor control (terminals 6 & 7) must be installed so as to preclude a short-circuiting of conductors. The maximum permissible cable length at terminals 4, 5, 8, 9 is 1 m. Hazardous movement must only be initiated via output contacts 16-17 and 20-21. Output 18 - 19 serves as a control channel and is not permissible for initiating hazardous movement. The output contacts are potential-free, monitored, force-guided, and normally open with a maximum loading capacity of 2 A/250 VAC or 60 VDC, 30 W. If an inductive load is employed, it (not the contacts) must be connected in parallel with spark quenching elements (for example, 0.22 µF, 220 Ω). If the sum of the currents through terminals 17 & 21 exceeds 2A, each contact must be protected by M 2.0 A. To increase switching safety, double contacts should be employed at terminals 4, 5, 6, 7, 8, 9, 10, 11, D, and 22. No extraneous potential should be connected to these terminals. If electric welding needs to be performed on the machine, pull out the controller's terminal strip to prevent stray welding currents from damaging the integrated electronics.

6.2 Cyclic mode "A" Protective mode with control of machine movement through cyclic infiltration of the protective field with 30-second work monitoring (for example, manual insertion for control of presses with a table height of more than 750 mm or revolving transfer tables)

Start-up test Following activation of the protective unit, conduct a one-time start-up test by infiltrating the protective field.

Start of machine movement If the start button is then actuated with the protective field cleared, accompanied by single or double infiltration and subsequent clearing, output contacts (16-17, 20-21) close and the machine starts moving.

Through brief interruption of terminals 10 - 11 (at least 20 ms) by means of a cam switch, for example, the cycle counting circuit is reset and the output contacts (16-17, 20-21) are opened. While terminals 10 -11 remain interrupted, infiltration can be performed safely and as often as necessary because the output contacts remain open and cycle counting is only resumed on closure of the switch.

After closure of the switch and subsequent single or double intervention in the protective field, the output contacts (16-17, 20-21) close again and the machine starts moving once more.

Work monitoring (with bridge 5-11). If the protective field is not infiltrated or released within 30 seconds of commencement of cycle counting, the work monitoring unit activates the restart interlock. In other words, machine movement is not commenced again until actuation of the start button with the protective field cleared.

End of hazardous movement If the protective field is infiltrated while the press is executing hazardous closure, the

press returns immediately to its top dead centre.

Restart interlock A new work cycle is possible only following actuation of the start button and test of the light barrier through single or double infiltration of the protective field.

Contactor / valve control (EDM) Before every release of the switching outputs, control terminals 6-7 are used to monitor the hydraulic valves or the contactors intended to commence hazardous movement. A new work cycle or hazardous movement can only be commenced if both contactors or valves K1 / K2 were released on infiltration of the protective field prior to it being cleared again.

Switchover between 1-cycle and 2-cycle On a switchover between the 1-cycle and 2-cycle operating modes, the restart interlock needs to be activated according to EN 61496. This can be realized by deactivating the transmitter during switchover.



In this state, it should not be possible to step behind the light curtain!

Additional connection for selector switch mode "A"

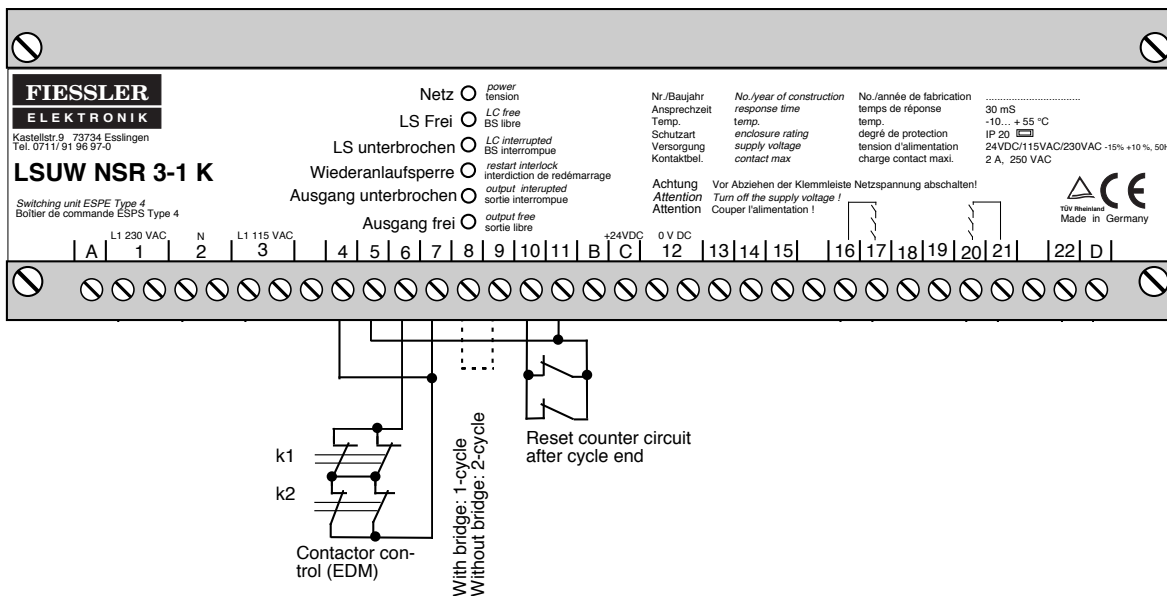

6.3 Protective mode with restart interlock during the "B" cycle

For applications involving cyclic manual infiltration of the protective field and restart by means of a start button.

Refer to ZH 1/281 and ZH 1/597, for instance. Possible applications include presses with a table height of less than 750 mm without an auxiliary protective unit, presses without a control system, rapid stamping machines which can dispense with cyclic testing.

Start-up test Following activation of the protective unit, conduct a one-time start-up test by infiltrating the protective field.

Start of machine movement If the start button is then actuated with the protective field cleared, output contacts (16-17, 20-21) close and the machine starts moving.

End of hazardous movement If the protective field is infiltrated, contacts 16-17 and 20-21 open and the machine comes to a stop.

Restart interlock A new work cycle is possible only following actuation of the start button.

Contactor / valve control (EDM) Before every release of the

switching outputs, control terminals 6-7 are used to monitor the hydraulic valves or the contactors intended to commence hazardous movement. Machine restart through actuation of the start button is only possible if both contactors or valves K1 / K2 were released on infiltration of the protective field prior to it being cleared again.



The start button should be mounted to permit a clear view of the hazard zone from the button's location, and preclude actuation from the hazard zone without interruption of the light barrier.

Additional connection for selector switch mode "B"

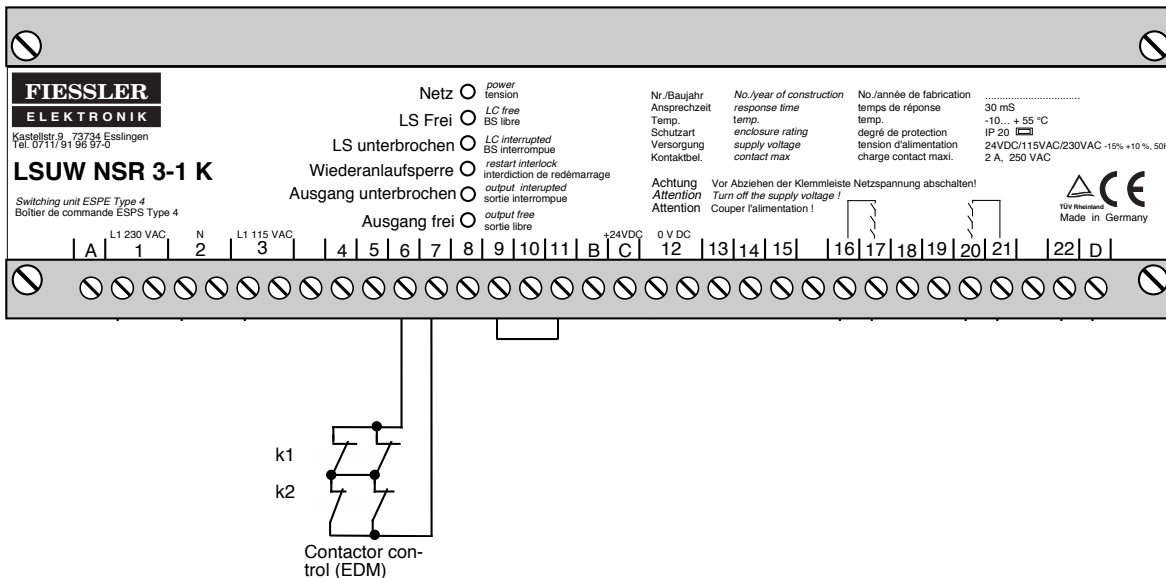

Selector switch mode "AB"

6.4 Selector switch mode "AB" (switchover between cyclic operation and protective mode with restart interlock)

Function

The mode selection switch WS can be used to set one of the following three operating modes: 1-cycle, 2-cycle or protective mode with restart interlock.

Refer to Chapter 6.2 for 1-cycle and 2-cycle operation; refer to Chapter 6.3 for protective mode with restart interlock

On switchover between these operating modes, the restart interlock must be activated according to EN 61494.



In the 1-cycle & 2-cycle modes, it must not be possible to step behind the light curtain.

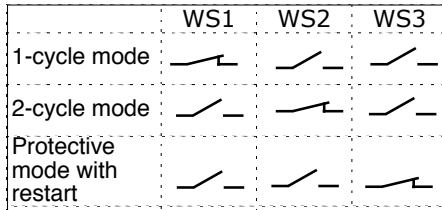

Additional or modified connections for selector switch mode "AB"

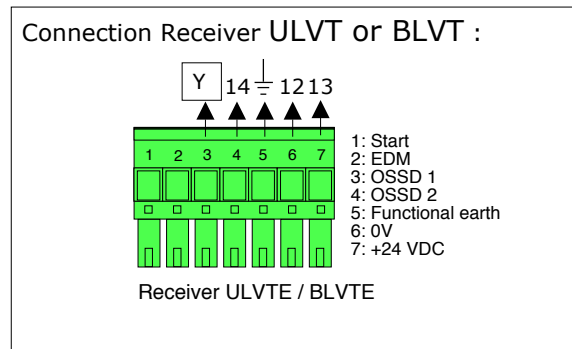
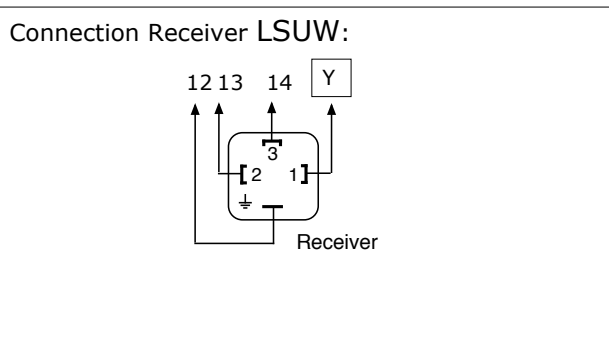
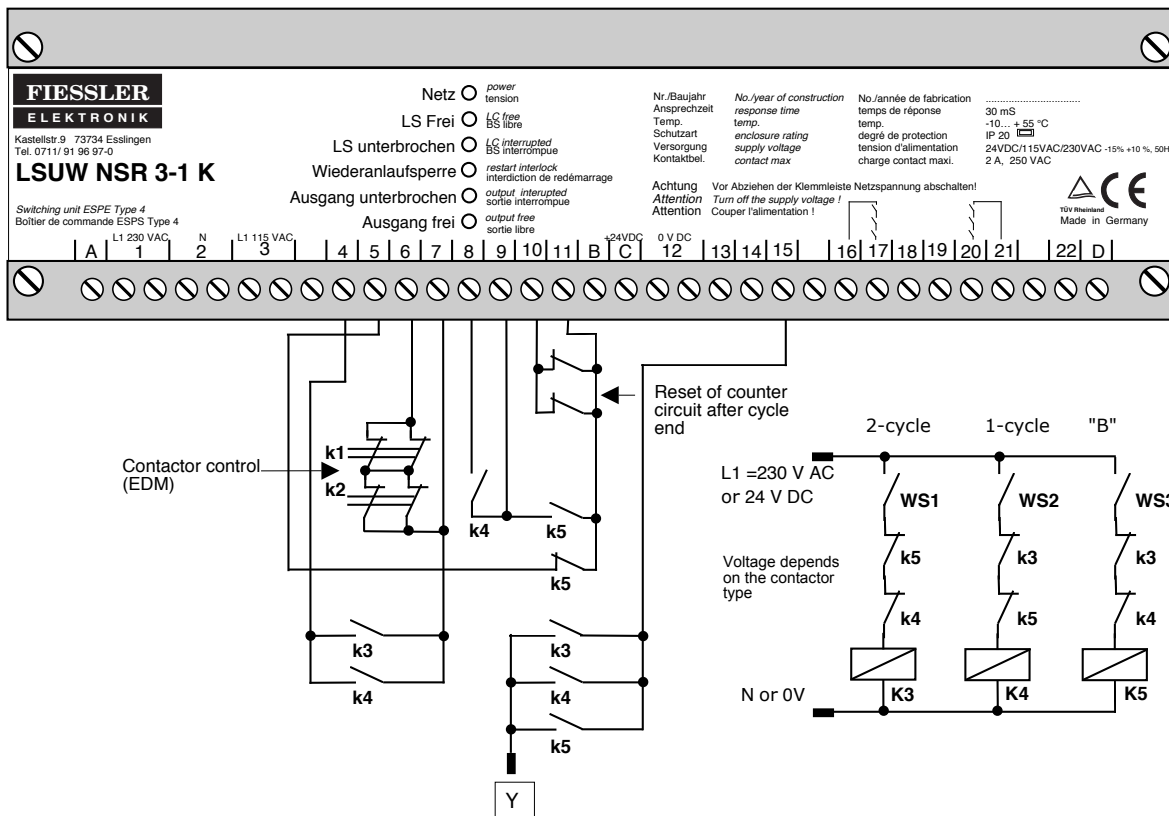

6.5 Protective mode with restart interlock during hazardous movement "B1" For example, for applications involving cyclic manual infiltration of the protective field during non-hazardous movement or at a standstill.

Start-up test Following activation of the protective unit, conduct a one-time start-up test by infiltrating the protective field.

Start of machine movement If the start button is then actuated with the protective field cleared, output contacts (16-17, 20-21) close and the machine starts moving.

End of hazardous movement If the protective field is infiltrated during hazardous movement of the machine, contacts 16-17 and 20-21 open and the machine comes to a stop.

Restart interlock A new work cycle is possible only following actuation of the start button.

Contactor / valve control (EDM) Control terminals 6-7 are

used to monitor the hydraulic valves or the contactors which commence hazardous movement. Machine restart through actuation of the start button is only possible if both contactors or valves K1 / K2 were released on infiltration of the protective field prior to it being cleared again.

If the machine is at a standstill or executing a safe, opening movement (open switch "S"), it can be infiltrated at any time without needing to re-actuate the start button.



In this operating mode, it should not be possible to step behind the light curtain!

Additional or modified connections for operating mode "B1"

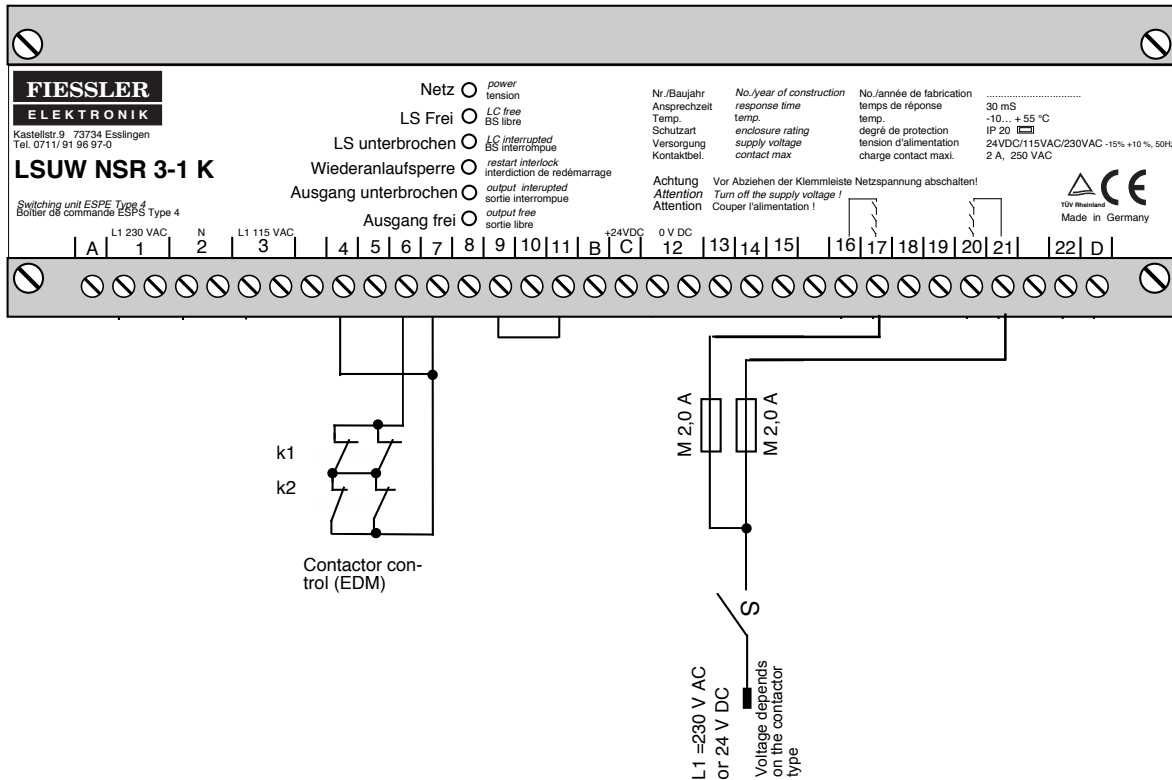

6.6 Protective mode without restart interlock / with valve or contactor control "C" For example, for protecting powered equipment or realizing restart interlock in the machine control unit.

Start-up test Following activation of the protective unit, conduct a one-time start-up test by infiltrating the protective field.

Start of machine movement Once the protective field is clear again, output contacts 16-17 and 20-21 close, and control contact 18-19 is interrupted. Output 18-19 serves as a control channel and is not permissible for initiating hazardous movement.

End of hazardous movement If the protective field is infiltrated, output contacts 16-17 & 20-21 open, control contact 18-19 closes and the machine comes to a stop.

used to monitor the contactors which initiate hazardous movement.



In this operating mode, it should not be possible to step behind the light curtain!

Contactor / valve control (EDM) Output contacts 6-7 are

Additional and modified connections for operating mode "C"

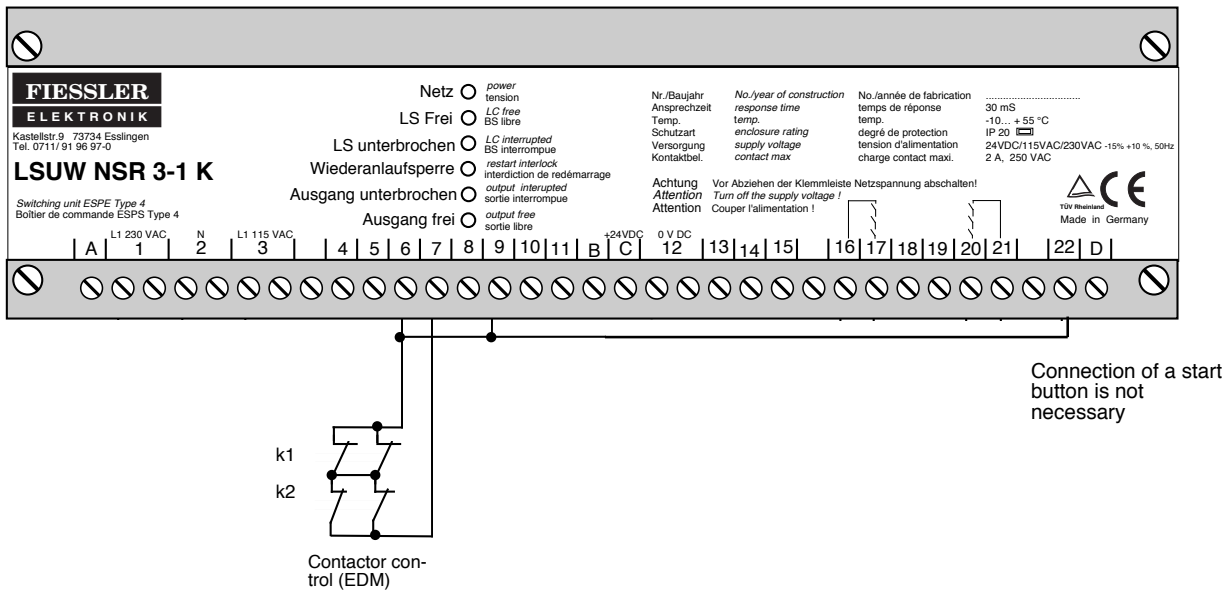

6.7 Protective mode with restart interlock and cyclic test "D"

For example, for rearward protection of presses without cyclic infiltration of the protective field. Refer to ZH 1/281, for example.

Cyclic test Normally, the protective field is infiltrated one or more times during every work cycle, thus testing the light barrier each time. During automatic execution, this infiltration test does not take place, sometimes for several hours. However, testing prior to each work cycle is often a prerequisite. In such cases, the machine must perform self-tests. For this purpose, a switch on the machine resets the counter circuit by briefly interrupting terminal 10-11 (for about 20 ms) and deactivates outputs 16-17 and 20-21. A wipe pulse at least 60 ms long interrupts the power supply to the light transmitter.

Start-up test Following activation of the protective unit, conduct a one-time start-up test by infiltrating the protective field.

Start of machine movement If the start button is then actuated with the protective field cleared, accompanied by one-time interruption and release, the current path 16-17 and 20-21 closes and the machine starts moving.

Contactor / valve control (EDM) Control terminals 6-7 are used to monitor the hydraulic valves or the contactors which

commence hazardous movement. A new work cycle or movement can only be commenced if both contactors or valves K1 / K2 were released on infiltration of the protective field prior to it being cleared again.

Output 18-19 serves as a control channel and is not permissible as a contact for initiating hazardous movement.

The contacts designated "Start button" (terminal D-22), "Reset counter circuit" (terminal 10-11) and "Monitoring NC" (terminal 6-7) are used to connect low voltages at low currents. These contacts must be potential-free and appropriately dimensioned (twin contacts wherever possible).



In this operating mode, it should not be possible to step behind the light curtain!

Additional and modified connections for operating mode "D" (only for LSUW light curtain)

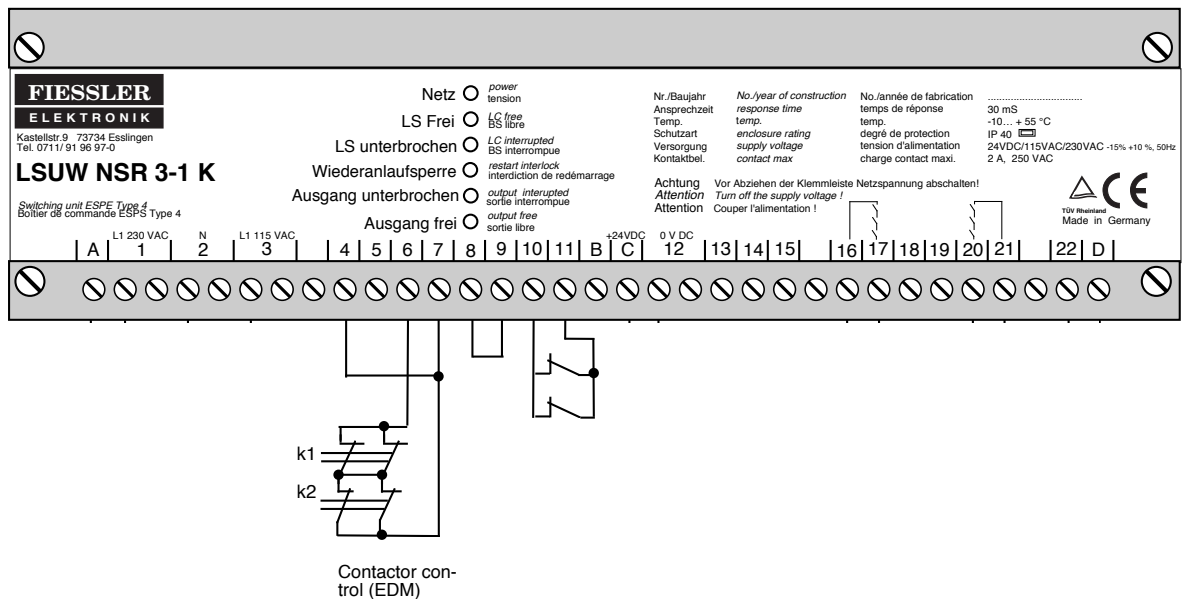

Connection of LSUW light transmitter:

Transmitter = 230 VAC version

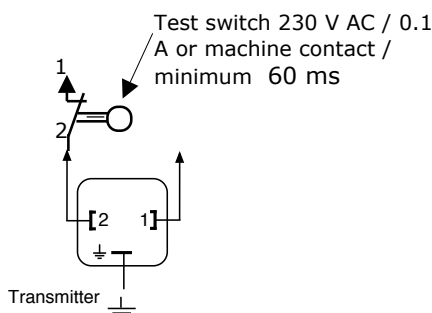

Transmitter = 24 VDC (special) version

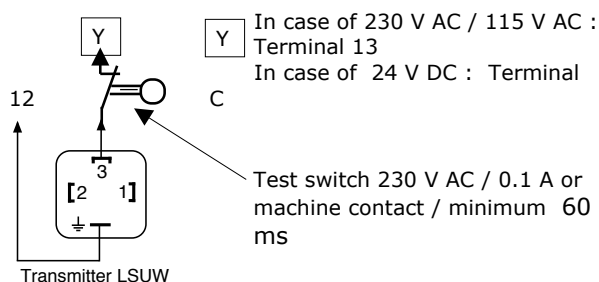

6.8 Dimensioning drawings of LSUW NSR 3-1 K

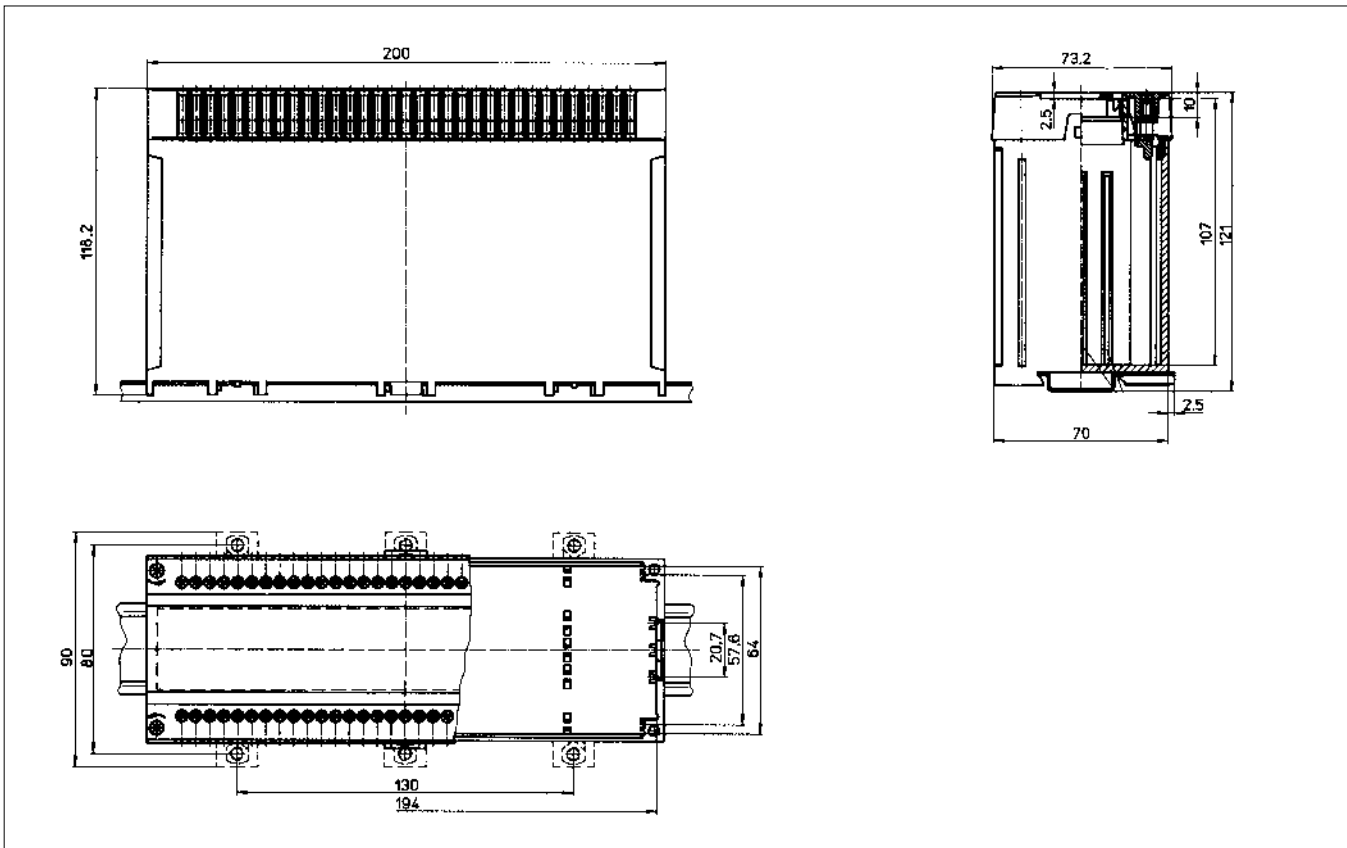

6.9 Technical specifications of safety controller LSUW NSR 3-1 K

Characteristic data

Safety category	4 according to EN 954-1 and IEC 61496 or EN 61496
Functions	<ul style="list-style-type: none"> - Cyclic operation - With / without restart interlock - Restart interlock only during hazardous movement - Contactor / valve control - Selector switch mode (switchover between cyclic mode and protective mode with restart interlock)
Response time	25 ms + response time of light curtain/light barrier

Mechanical data

Housing design	Black insulating material, beige cover
Fastening	Snap-on fastening on a hat rail (DIN EN 50022-35), screw fastening
Weight	1700 g

Operational data

Protection type	IP 20
Protection class	Protective insulation
Ambient operating temperature	-10 to 55 °C
Storage temperature	-25 to 70 °C

Electrical data

Supply voltage	230 V AC/50Hz +10% -15%, 115 V AC/50Hz +10% -15% or 24 V DC, +20% - 10%, protected against reverse polarity
Outputs	The output contacts are potential-free, monitored, force-guided and normally open with a maximum loading capacity of 2 A/250 V AC or 60 V DC, 30 W.
Electrical connection	Plug-in terminal strip
Connection cable	Max. 1,5 mm ²

6.10 Notes

6.10 Notes

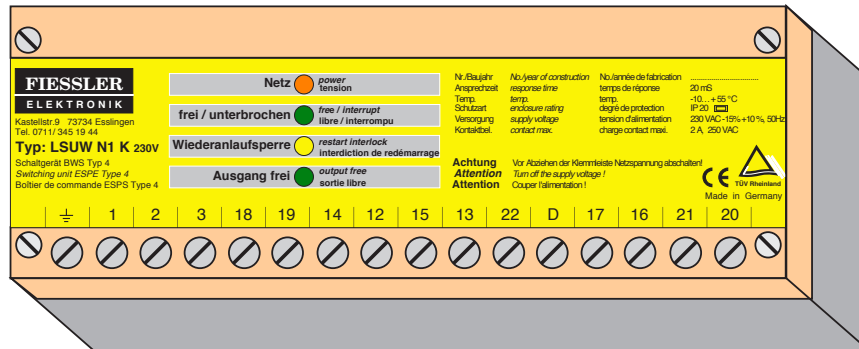

LSUW N1 K
230 VAC version

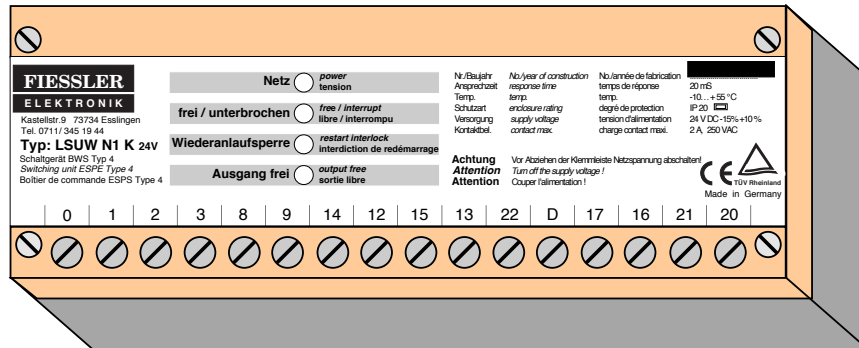

LSUW N1 K
24 VDC version

Chapter Contents

Page

7.	LSUW N1 K controller	53
7.1	Connection of LSUW N1K <u>with</u> restart interlock / <u>with</u> contactor control (EDM) - <u>230 VAC version</u>	54
7.2	Connection of LSUW N1K <u>with</u> restart interlock / <u>with</u> contactor control (EDM) - <u>24 VDC version</u>	55
7.3	Dimensional drawings	56
7.4	Technical data	57
7.5	Notes	58

7.2 Connection of LSUW N1 K with restart interlock / with contactor control (EDM)

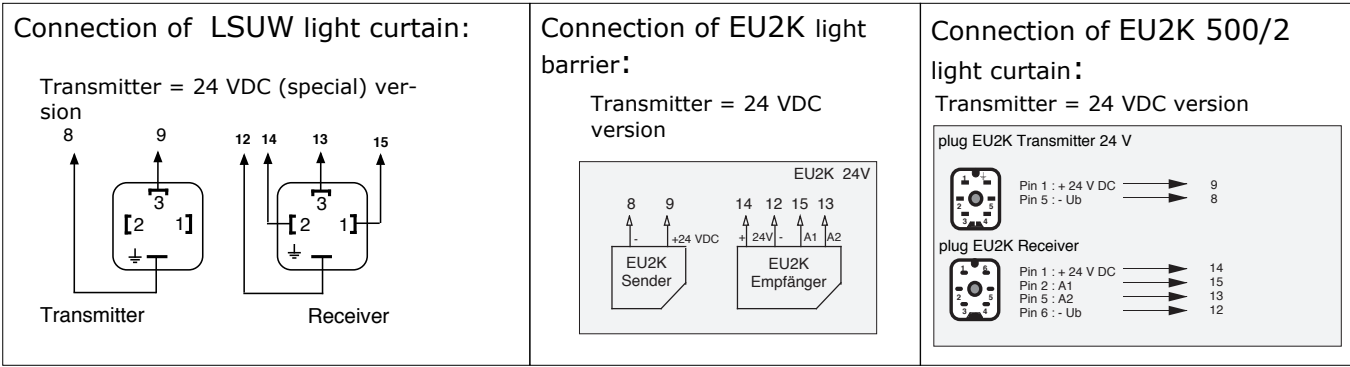
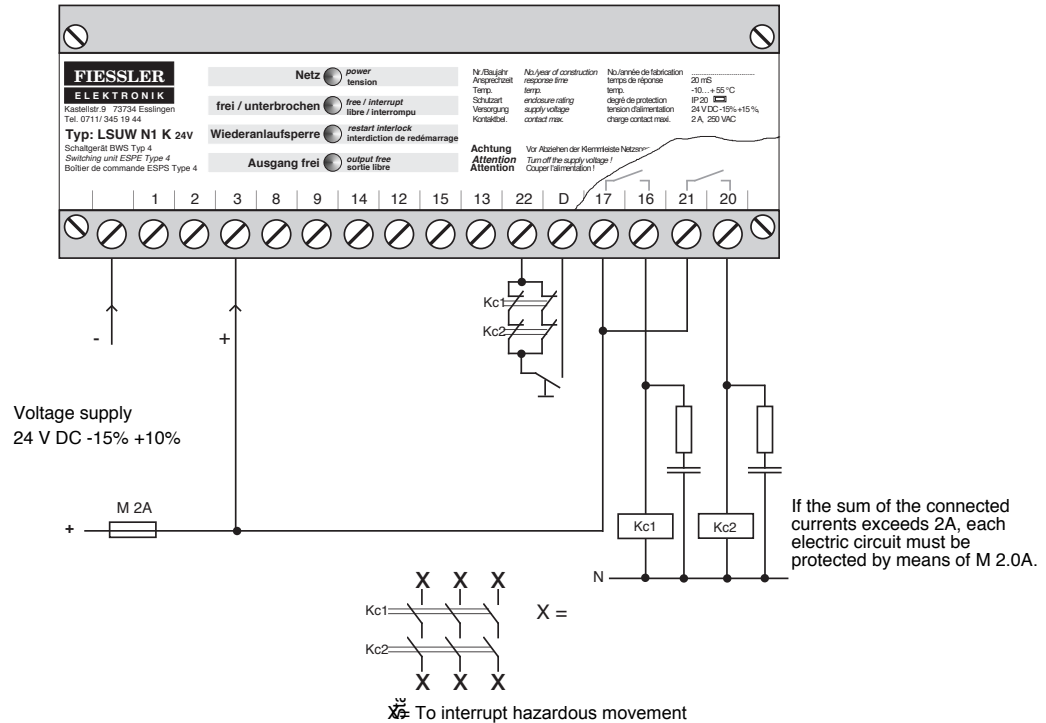

The transmitter is activated by actuating the start button.
The control LED on the transmitter lights up. If the protective field is free, the receiver LED shines green and the controller LED indicates that the field is clear.
On release of the start button, outputs 16-17 and 20-21 are switched through and the transmitter control assumes the self-holding state. The LED for indicating a free output comes on.
If the protective field is infiltrated, outputs 16-17 and 20-21 are deactivated.

The NC contacts of contactors Kc 1 and Kc 2 connected in series with the start button are used to monitor the contactor functionality.

Note:
During adjustment, the start button must be pressed continuously or bypassed.

The start button should be mounted to permit a clear view of the hazard zone from the button's location, and preclude actuation from the hazard zone without interruption of the light barrier.

Restart is possible only following release of the protective field and actuation of the start button.

7.3 Dimensional drawing of LSUW N1 K

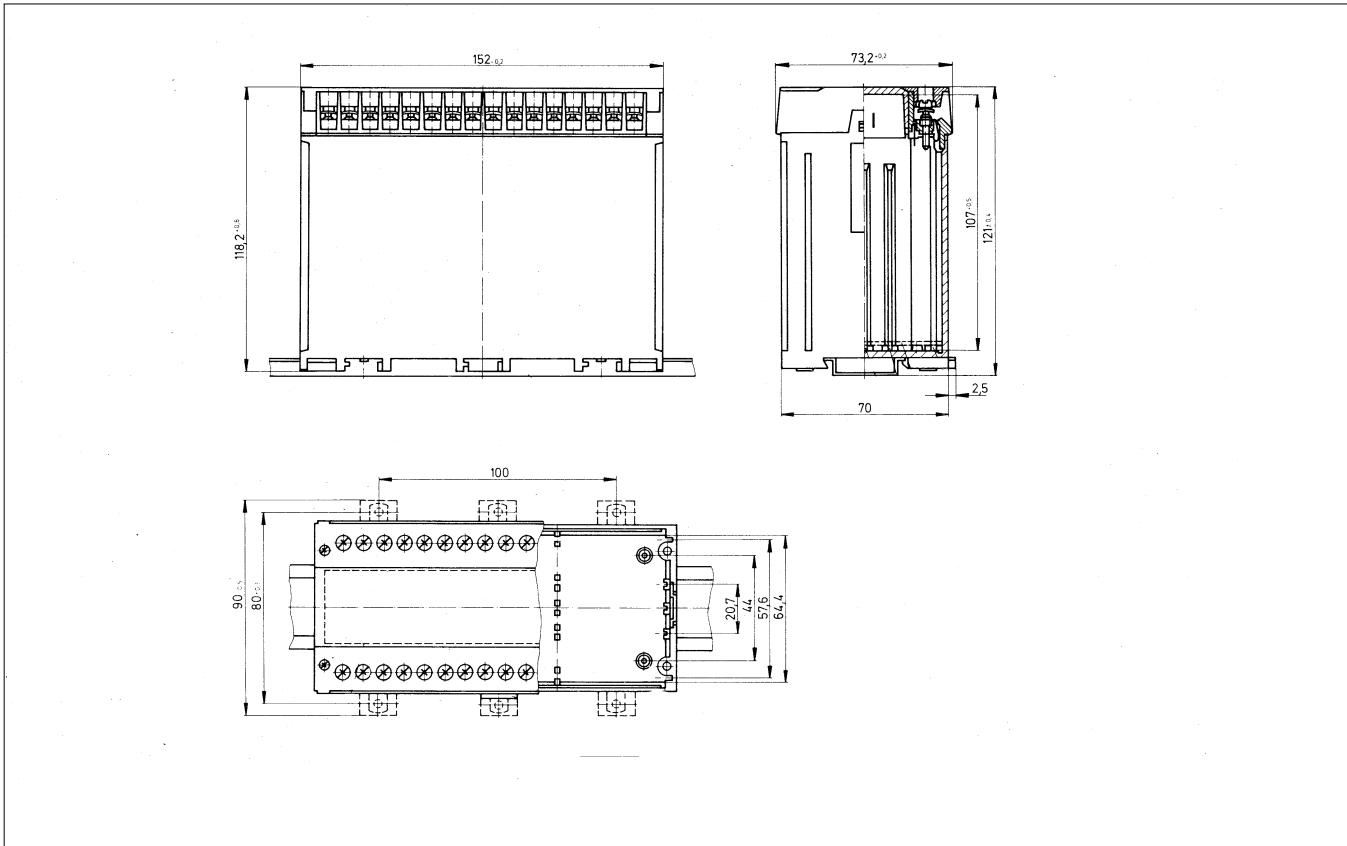

7.4 Technical specifications of safety controller LSUW N1 K

Characteristic data

Safety category	4 according to EN 954-1 and IEC 61496 or EN 61496
Functions	- Restart interlock - Contactor / valve control
Response time	20 ms including light curtain

Mechanical data

Housing design	Black insulating material, beige cover
Fastening	Snap-on fastening on a hat rail (DIN EN 50022-35), screw fastening
Weight	1200 g

Operational data

Protection type	IP 20
Protection class	Protective insulation
Ambient operating temperature	-10 to 55 °C
Storage temperature	-25 to 70 °C

Electrical data

Supply voltage	230 V version: 230 V AC/50Hz +10% -15%; 24 V version: 24 V DC, + 10% - 15%, protected against
Outputs	The output contacts are potential-free, monitored, force-guided and normally open with a maximum loading capacity of 2 A/250 V AC or 60 V DC, 30 W.
Electrical connection	Plug-in terminal strip
Connection cable	Max. 1,5 mm ²

7.5 Notes

- 1.
- 2.
- 3.
- 4.
- 5.
- 6.
- 7.

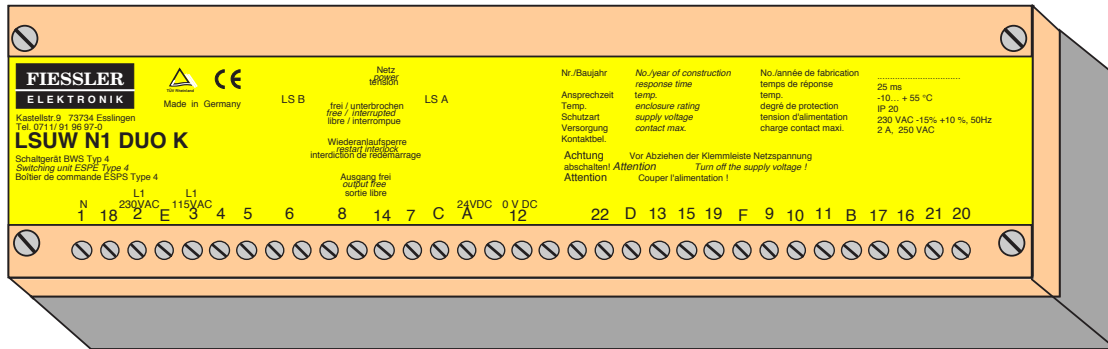

Chapter Contents

Page

8. LSUW N1 DUO K controller

8.1	Safeguarding of a hazard zone with two light barriers	
8.1.1	Connection of LSUW N1 DUO K	
	<u>with</u> restart interlock / <u>with</u> contactor control (EDM) 230 VAC connection.....	60
8.1.2	Connection of LSUW N1 DUO K	
	<u>with</u> restart interlock / <u>with</u> contactor control (EDM) 24 VDC connection	61
8.2	Safeguarding of 2 independent hazard zones	
8.2.1	Connection of LSUW N1 DUO K	
	<u>with</u> restart interlock / <u>with</u> contactor control (EDM) 230 VDC connection	62
8.2.2	Connection of LSUW N1 DUO K	
	<u>with</u> restart interlock / <u>with</u> contactor control (EDM) 24 VDC connection.....	63
8.3	Dimensional drawings	64
8.4	Technical data	65
8.5	Notes	66

230 VAC /115 VAC connec-

8.1 Safeguarding of one hazard zone with two light barriers (1 start button) 8.1.1 Connection of LSUW N1 DUO K with restart interlock / with contactor control (EDM) Safeguarding of a hazard zone accessible from one side by means of two light barriers.

⚠ The two light barriers must be mounted so that each receiver sees only its dedicated transmitter.

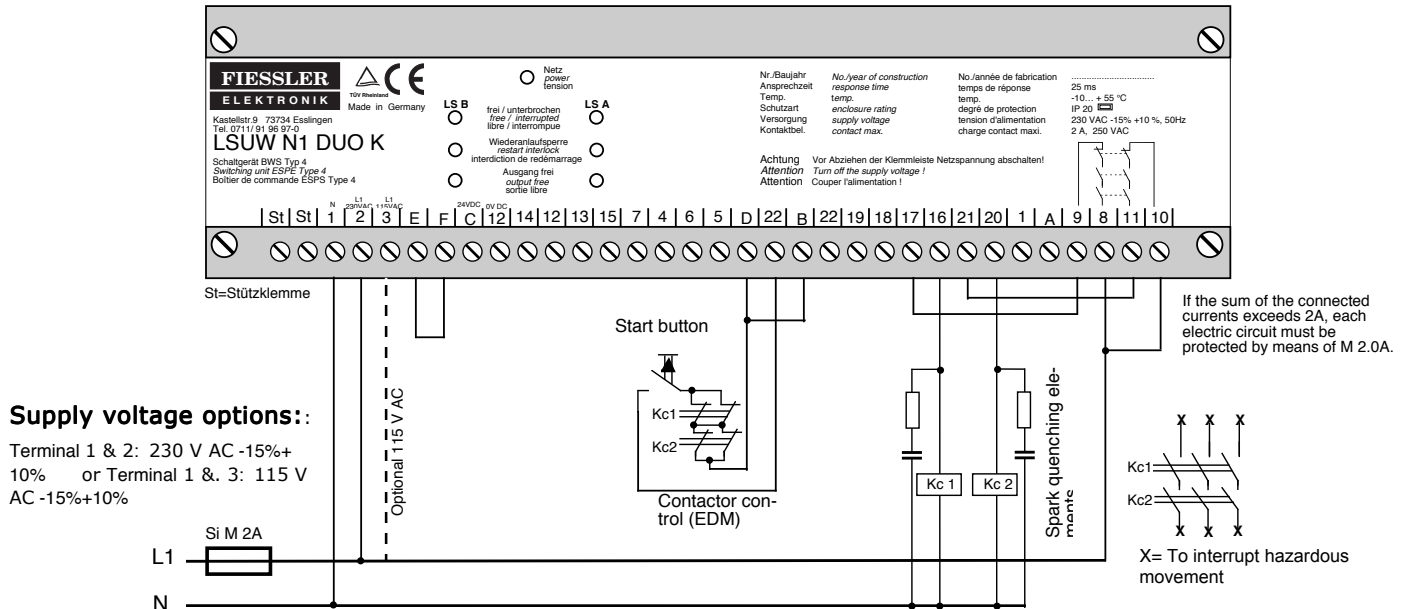

Connection of 2 light curtains LSUW:

Transmitter = 230 VAC version

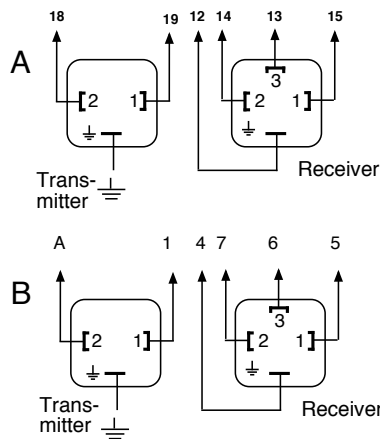

Connection of 2 light barriers EU2K:

Transmitter = 230 VAC ver-

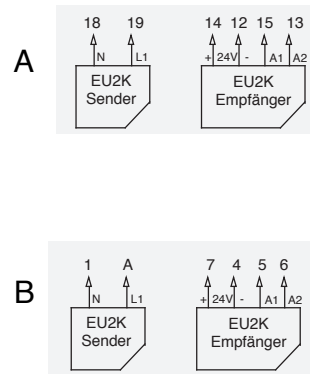

Connection of 2 light curtains EU2K 500/2:

Transmitter = 230 VAC version

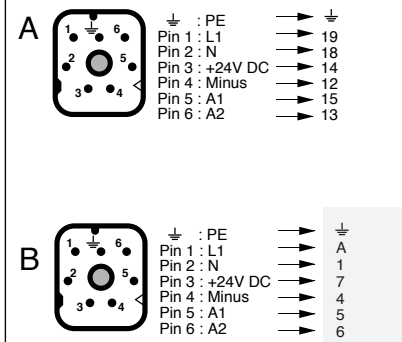

Actuating the start button activates transmitters A and B. The monitoring LEDs on the transmitters come on. If the protective fields are clear, the LEDs on the corresponding receivers shine green and the controller LEDs indicate that the field is clear.

On release of the start button, outputs "A" 16-17 and 20-21, as well as "B" 8-9 and 10-11 are switched through and the transmitter control assumes the self-holding state. The LEDs for indicating a free output come on.

Both light barriers are connected in series. Contactors Kc1 and Kc2 are deactivated on infiltration of one or both protective fields.

Restart is possible only following release of both protective fields and actuation of the start button.

The NC contacts of contactors Kc 1 and Kc 2 connected in series with the start button are used to monitor the contactor functionality.

Note: During adjustment, the start button must be pressed continuously or bypassed.

The start button should be mounted to permit a clear view of the hazard zone from the button's location, and preclude actuation from the hazard zone without interruption of a light barrier.

8.1.2 Connection of LSUW N1 DUO K with restart interlock / with contactor control (EDM) Safeguarding of a hazard zone accessible from one side by means of two light barriers (1 start button).

! The two light barriers must be mounted so that each receiver sees only its dedicated transmitter.

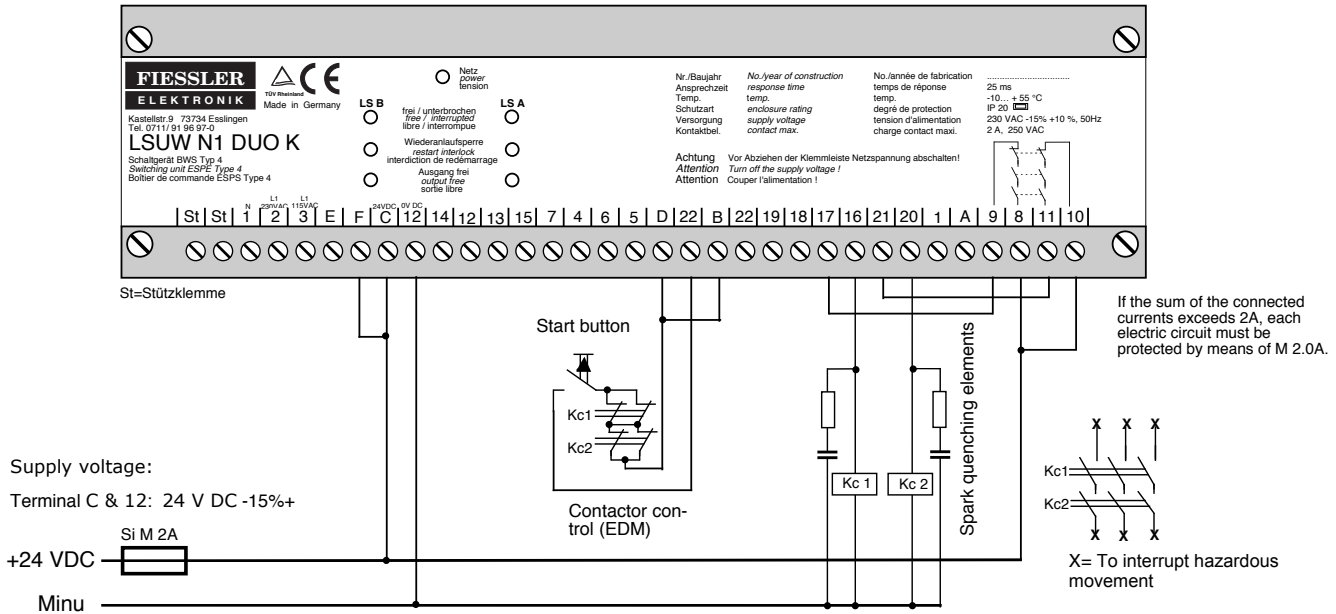

Connection of 2 light curtains LSUW:

Transmitter = 24 VDC (special) version

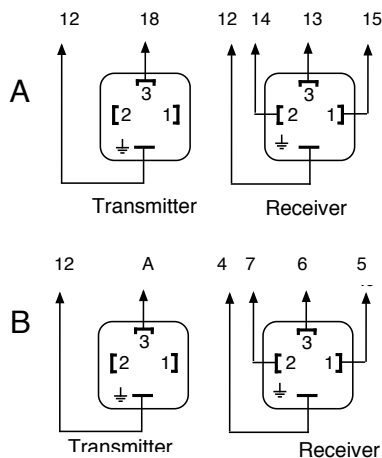

Connection of 2 light barriers EU2K:

Transmitter = 24 VDC version

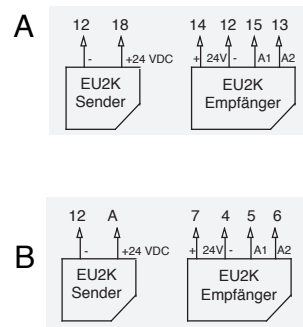

Connection of 2 light curtains EU2K 500/2:

Transmitter = 24 VDC version

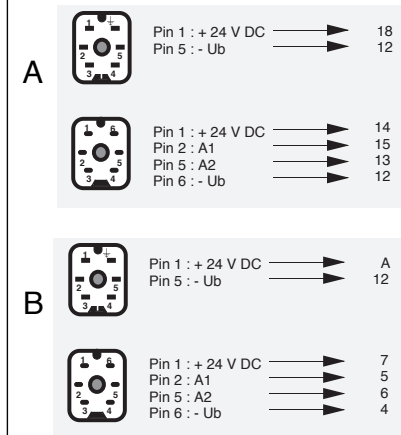

Actuating the start button activates transmitters A and B.

The monitoring LEDs on the transmitters come on. If the protective fields are clear, the LEDs on the corresponding receivers shine green and the controller LEDs indicate that the fields are clear.

On release of the start button, outputs "A" 16-17 and 20-21, as well as "B" 8-9 and 10-11 are switched through and the transmitter control assumes the self-holding state. The LEDs for indicating a free output come on.

Both light barriers are connected in series. Contactors Kc1 and Kc2 are deactivated on infiltration of one or both protective fields.

Restart is possible only following release of both protective fields and actuation of the start button.

The NC contacts of contactors Kc 1 and Kc 2 connected in series with the start button are used to monitor the contactor functionality.

Note: During adjustment, the start button must be pressed continuously or bypassed.

The start button should be mounted to permit a clear view of the hazard zone from the button's location, and preclude actuation from the hazard zone without interruption of a light barrier.

8.2 Safeguarding of 2 independent hazard zones (2 start buttons) 8.2.1 Connection of LSUW N1 DUO K with restart interlock / with contactor control (EDM) Safeguarding of two independent hazard zones or one hazard zone accessible from two sides.

! The two light barriers must be mounted so that each receiver sees only its dedicated transmitter.

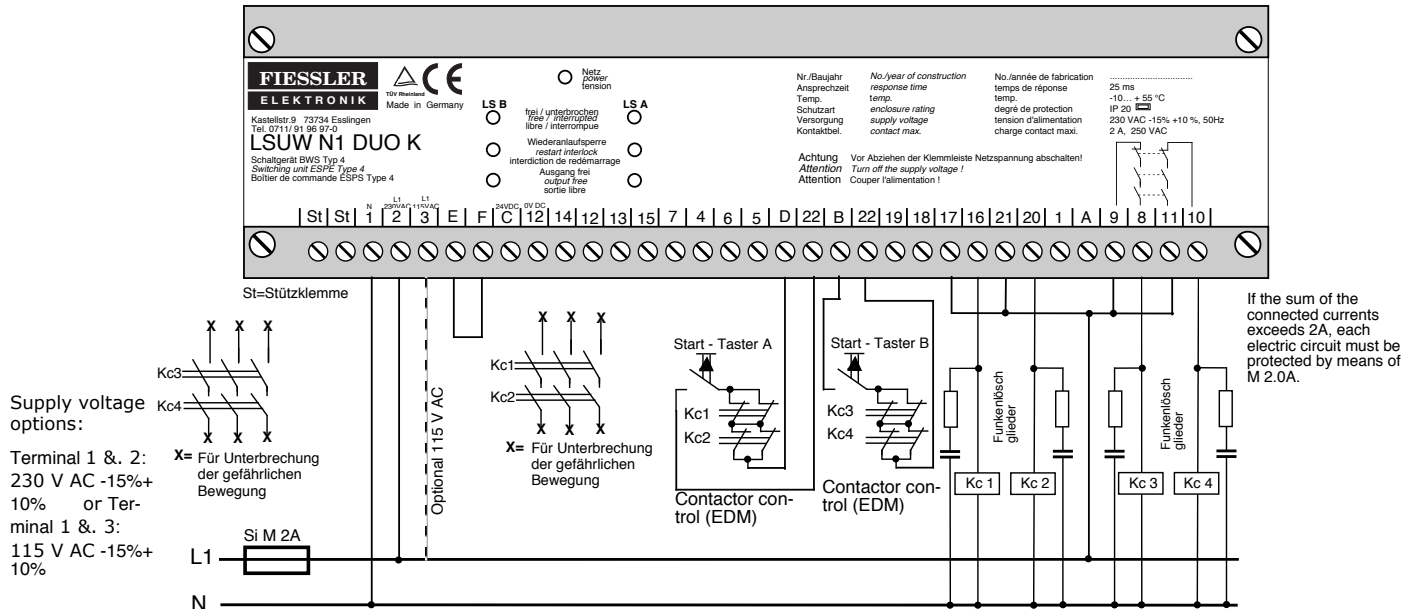

Connection of 2 light curtains LSUW:

Transmitter = 230 VAC version

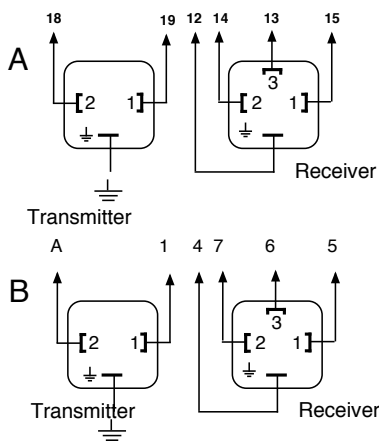

Connection of 2 light barriers EU2K:

Transmitter = 230 VAC version

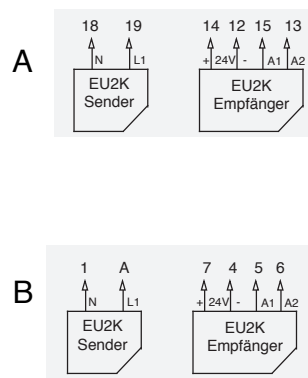

Connection of 2 light curtains EU2K 500/2:

Transmitter = 230 VAC version

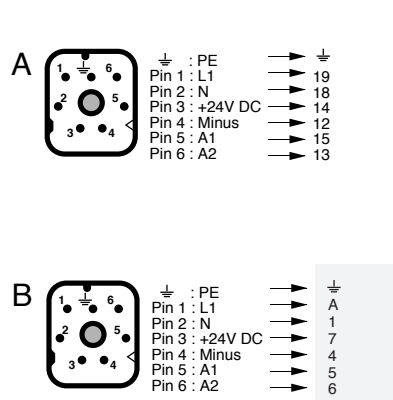

Actuating start buttons A and B activates the corresponding transmitters A and B.

The monitoring LEDs on the transmitters come on. If the protective field is clear, the LEDs on the corresponding receivers shine green and the controller LEDs indicate that the field is clear.

On release of the start button, outputs "A" 16-17 and 20-21, as well as "B" 8-9 and 10-11 are switched through and the transmitter control assumes the self-holding state. The LEDs for indicating a free output come on.

If the protective field is infiltrated, the corresponding outputs are deactivated.

Restart is possible only following release of the protective field and actuation of the corresponding start button.

The NC contacts of contactors Kc 1 & Kc 2 as well as Kc3 & Kc4 connected in series with the corresponding start buttons are used to monitor the contactor functionality.

Note: During adjustment, the start button must be pressed continuously or bypassed. Each start button should be mounted to present a clear view of the hazard zone from the button's location, and preclude actuation from the hazard zone without interruption of a light barrier.

8.2.2 Connection of LSUW N1 DUO K with restart interlock / with contactor control (EDM) Safeguarding of two independent hazard zones or one hazard zone accessible from two sides (2 start buttons).

⚠ The two light barriers must be mounted so that each receiver sees only its dedicated transmitter.

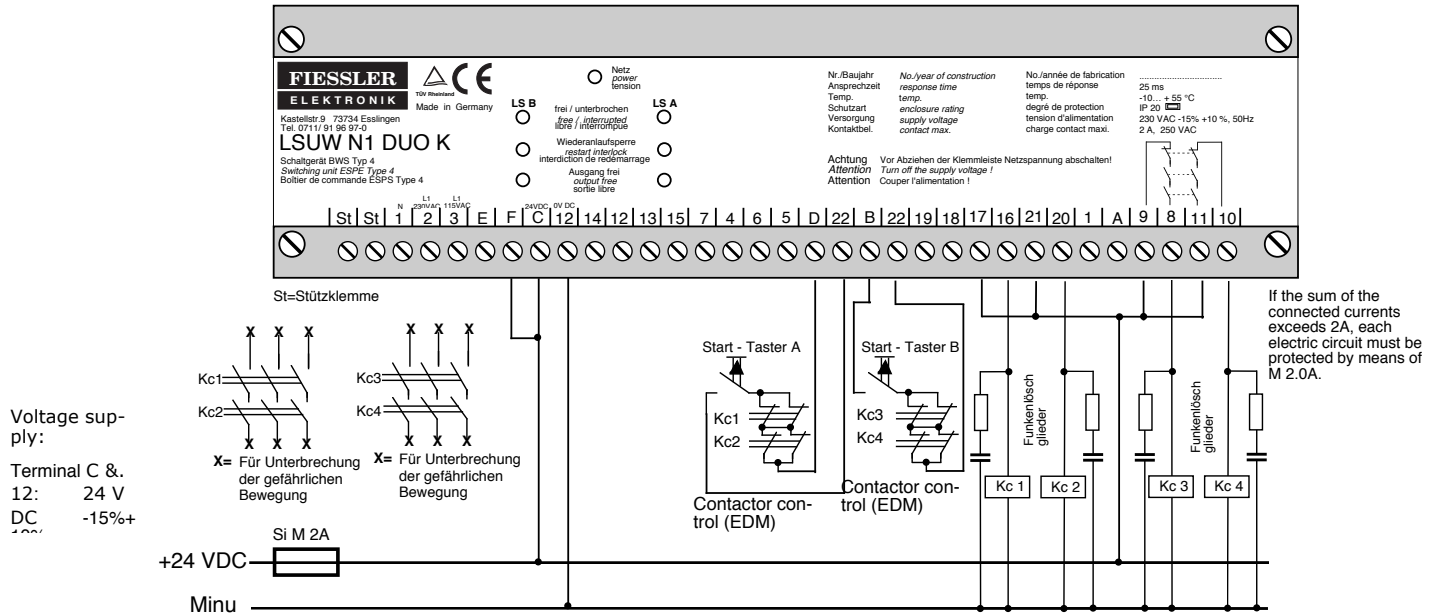

Connection of 2 light curtains LSUW:

Transmitter = 24 VDC (special) version

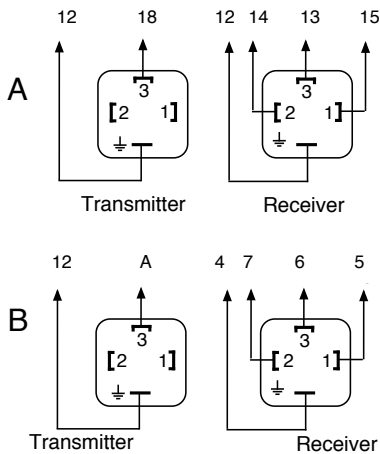

Actuating start buttons A and B activates the corresponding transmitters A and B.

The monitoring LEDs on the transmitters come on. If the protective field is clear, the LEDs on the corresponding receivers shine green and the controller LEDs indicate that the field is clear.

On release of the start button, outputs "A" 16-17 and 20-21, as well as "B" 8-9 and 10-11 are switched through and the transmitter control assumes the self-holding state. The LEDs for indicating a free output come on.

If the protective field is infiltrated, the corresponding outputs are deactivated.

Restart is possible only following release of the protective field and actuation of the corresponding start button.

Connection of 2 light barriers EU2K:

Transmitter = 24 VDC version

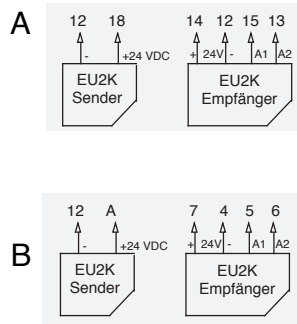

Connection of 2 light curtains EU2K 500/2:

Transmitter = 24 VDC version

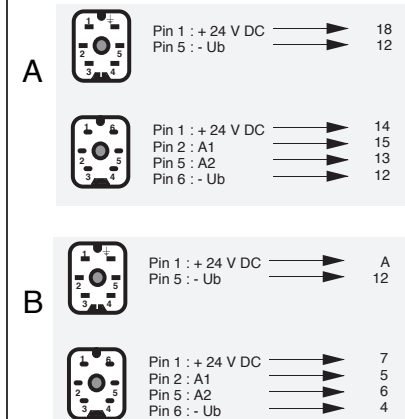

The NC contacts of contactors Kc 1 & Kc 2 as well as Kc3 & Kc4 connected in series with the corresponding start buttons are used to monitor the contactor functionality.

Note: During adjustment, the start button must be pressed continuously or bypassed. Each start button should be mounted to permit a clear view of the hazard zone from the button's location, and preclude actuation from the hazard zone without interruption of a light barrier.

8.3 Dimensional drawings of LSUW N1 DUO K

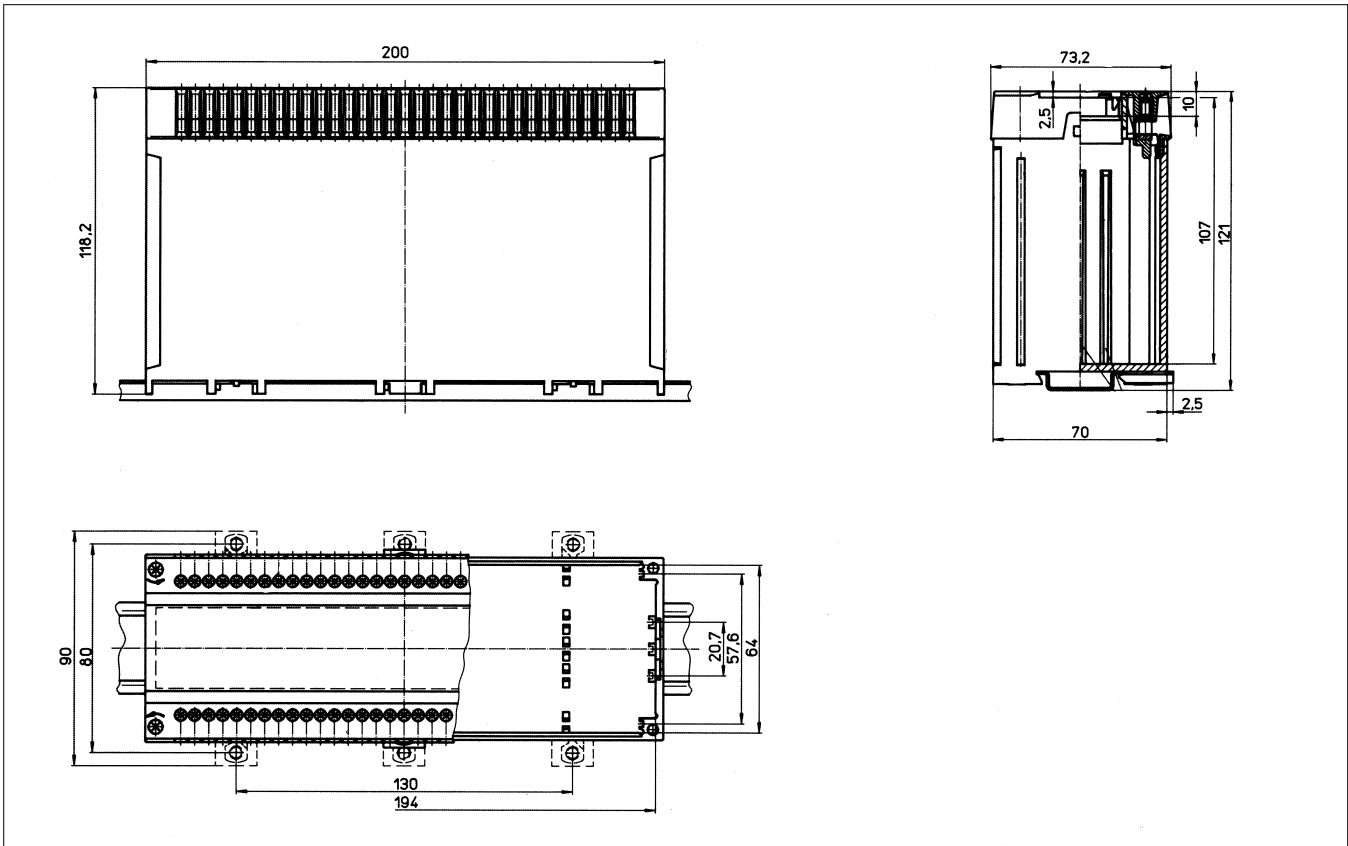

8.4 Technical specifications of safety controller LSUW N1 DUO K

Characteristic data

Safety category	4 according to EN 954-1 and IEC 61496 or EN 61496
Operating modes (also refer to Chapter 7)	- Restart interlock - Contactor / valve control
Response time	20 ms including light curtain

Mechanical data

Housing design	Black insulating material, beige cover
Fastening	Snap-on fastening on a hat rail (DIN EN 50022-35), screw fastening
Weight	1700 g,

Operational data

Protection type	IP 20
Protection class	Protective insulation
Ambient operating temperature	-10 to 55 °C
Storage temperature	-25 to 70 °C

Electrical data

Supply voltage	230 V AC/50Hz +10% -15%, 115 V AC/50Hz +10% -15% or 24 V DC, + 10% - 15%, protected against reverse polarity
Outputs	The output contacts are potential-free, monitored, force-guided and normally open with a maximum loading capacity of 2 A/250 V AC or 60 V DC, 30 W.
Electrical connection	Plug-in terminal strip
Connection cable	Max. 1,5 mm ²

8.5 Notes

Service

If you have any questions that cannot be answered by reading this operating manual, please contact us directly.

When calling, please have the following details ready:

- Device designation
- Serial number
- Fault symptoms and description

Fiessler Elektronik Buchenteich 14 D-73773 Aichwald

Phone: +49-711-919697-0

Fax: +49-711-919697-50

E-mail: info@fiessler.de

Returning a unit

If a unit proves defective and needs to be returned, the following details will greatly help us in repairing the fault quickly:

- Exact fault description
 - Has the machine furnished with the light curtain exhibited other faults?
 - Have you noticed any other failures in the past?
 - In which operating mode was the unit last used?

The more precise the fault description, the more efficiently and reliably we will be able to pinpoint and eliminate the fault.

Download area

The latest operating manuals, device descriptions etc. can be downloaded free-of-charge from our homepage.

<http://www.fiessler.de>

Delivery program

Fiessler Elektronik
 Buchenteich, 14 D-73773 Aichwald
 Telefon: 0711 / 91 96 97-0
 Telefax: 0711 / 91 96 97-50
 WWW.fiessler.de
 E-Mail: info@fiessler.de

